

About this Manual

We've added this manual to the Agilent website in an effort to help you support your product. This manual is the best copy we could find; it may be incomplete or contain dated information. If we find a more recent copy in the future, we will add it to the Agilent website.

Support for Your Product

Agilent no longer sells or supports this product. Our service centers may be able to perform calibration if no repair parts are needed, but no other support from Agilent is available. You will find any other available product information on the Agilent Test & Measurement website, www.tm.agilent.com.

HP References in this Manual

This manual may contain references to HP or Hewlett-Packard. Please note that Hewlett-Packard's former test and measurement, semiconductor products and chemical analysis businesses are now part of Agilent Technologies. We have made no changes to this manual copy. In other documentation, to reduce potential confusion, the only change to product numbers and names has been in the company name prefix: where a product number/name was HP XXXX the current name/number is now Agilent XXXX. For example, model number HP8648A is now model number Agilent 8648A.

HP 84125C

User's Guide

Microwave EMI Measurement Test System



HP Part No. 84125-90010
Printed in USA February 1999

Notice

The information contained in this document is subject to change without notice.

Hewlett-Packard makes no warranty of any kind with regard to this material, including but not limited to, the implied warranties of merchantability and fitness for a particular purpose. Hewlett-Packard shall not be liable for errors contained herein or for incidental or consequential damages in connection with the furnishing, performance, or use of this material.

Restricted Rights Legend

Use, duplication, or disclosure by the U.S. Government is subject to restrictions as set forth in subparagraph (c) (1) (ii) of the Rights of Technical Data and Computer Software clause at DFARS 252.227-7013 for DOD agencies, and subparagraphs (c) (1) and (c) (2) of the Commercial Computer Software Restricted Rights clause at FAR 52.227-19 for other agencies.

© Copyright Hewlett-Packard Company 1997, 1999
All Rights Reserved. Reproduction, adaptation, or translation without prior written permission is prohibited, except as allowed under the copyright laws.
1400 Fountain Grove Parkway, Santa Rosa CA, 95403-1799, USA

Certification

Hewlett-Packard Company certifies that this product met its published specifications at the time of shipment from the factory. Hewlett-Packard further certifies that its calibration measurements are traceable to the United States National Institute of Standards and Technology, to the extent allowed by the Institute's calibration facility, and to the calibration facilities of other International Standards Organization members.

Regulatory Information

Regulatory information is located in Chapter 2.

Warranty

This Hewlett-Packard instrument product is warranted against defects in material and workmanship for a period of one year from date of shipment. During the warranty period, Hewlett-Packard Company will, at its option, either repair or replace products which prove to be defective.

For warranty service or repair, this product must be returned to a service facility designated by Hewlett-Packard. Buyer shall prepay shipping charges to Hewlett-Packard and Hewlett-Packard shall pay shipping charges to return the product to Buyer. However, Buyer shall pay all shipping charges, duties, and taxes for products returned to Hewlett-Packard from another country.

Hewlett-Packard warrants that its software and firmware designated by Hewlett-Packard for use with an instrument will execute its programming instructions when properly installed on that instrument. Hewlett-Packard does not warrant that the operation of the instrument, or software, or firmware will be uninterrupted or error-free.

LIMITATION OF WARRANTY

The foregoing warranty shall not apply to defects resulting from improper or inadequate maintenance by Buyer, Buyer-supplied software or interfacing, unauthorized modification or misuse, operation outside of the environmental specifications for the product, or improper site preparation or maintenance.

NO OTHER WARRANTY IS EXPRESSED OR IMPLIED. HEWLETT-PACKARD SPECIFICALLY DISCLAIMS THE IMPLIED WARRANTIES OF MERCHANTABILITY AND FITNESS FOR A PARTICULAR PURPOSE.

EXCLUSIVE REMEDIES

THE REMEDIES PROVIDED HEREIN ARE BUYER'S SOLE AND EXCLUSIVE REMEDIES. HEWLETT-PACKARD SHALL NOT BE LIABLE FOR ANY DIRECT, INDIRECT, SPECIAL, INCIDENTAL, OR CONSEQUENTIAL DAMAGES, WHETHER BASED ON CONTRACT, TORT, OR ANY OTHER LEGAL THEORY.

Assistance

Product maintenance agreements and other customer assistance agreements are available for Hewlett-Packard products. For any assistance, contact your nearest Hewlett-Packard Sales and Service Office.

Compliance

This instrument has been designed and tested in accordance with IEC Publication 348, Safety Requirements for Electronic Measuring Apparatus, and has been supplied in a safe condition. The instruction documentation contains information and warnings which must be followed by the user to ensure safe operation and to maintain the instrument in a safe condition.

Safety Notes

The following safety notes are used throughout this manual. Familiarize yourself with each of the notes and its meaning before operating this instrument.

WARNING

Warning denotes a hazard. It calls attention to a procedure which, if not correctly performed or adhered to, could result in injury or loss of life. Do *not* proceed beyond a warning note until the indicated conditions are fully understood and met.

CAUTION

Caution denotes a hazard. It calls attention to a procedure that, if not correctly performed or adhered to, would result in damage to or destruction of the instrument. Do *not* proceed beyond a caution sign until the indicated conditions are fully understood and met.

General Safety Considerations

WARNING

- No operator serviceable parts inside. Refer servicing to qualified personnel. To prevent electrical shock, do not remove covers.
- If this instrument is not used as specified, the protection provided by the equipment may be impaired. This instrument must be used in a normal condition (in which all means for protection are intact) only.
- For continued protection against fire hazard, replace line fuse only with same type and rating ([F 5A/250V]). The use of other fuses or material is prohibited.

CAUTION

- Before switching on this instrument, make sure that the line voltage selector switch is set to the voltage of the power supply and the correct fuse is installed.
- Always use the three-prong ac power cord supplied with this instrument. Failure to ensure adequate earth grounding by not using this cord may cause instrument damage.
- Only clean the instrument cabinet using a damp cloth.



The instruction documentation symbol. The product is marked with this symbol when it is necessary for the user to refer to the instructions in the documentation.

CE

The CE mark is a registered trademark of the European Community. (If accompanied by a year, it is when the design was proven.)

ISM1-A

This is a symbol of an Industrial Scientific and Medical Group 1 Class A product.

CSA

The CSA mark is a registered trademark of the Canadian Standards Association.

Manual Conventions

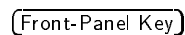
 Front-Panel Key

This represents a key physically located on the instrument.

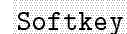
 Softkey

This indicates a “softkey,” a key whose label is determined by the firmware of the instrument.

Screen Text

This indicates text displayed on the instrument’s screen.

Contents

| | |
|--|------|
| 1. Product Description | |
| Measurement Overview | 1-2 |
| 2. Specifications and Characteristics | |
| Definition of Terms | 2-1 |
| HP 8564E Spectrum Analyzer Specifications and Characteristics | 2-2 |
| Antenna Specifications and Characteristics | 2-3 |
| Typical Sensitivity for an HP 84125C System | 2-5 |
| Amplitude Accuracy | 2-6 |
| Declaration of Conformity | 2-8 |
| 3. System Setup and Functional Tests | |
| System Setup | 3-1 |
| Initial Inspection | 3-1 |
| Test Set Components | 3-2 |
| Installing the HP 84125C System | 3-4 |
| Assembling the Test Mobile Instrument Cart | 3-4 |
| Installing the Spectrum Analyzer | 3-4 |
| Attaching the Power Module and Power Cords | 3-6 |
| Installing the Accessories and Test Set in the System | 3-6 |
| Connecting the RF Cable Assembly to the Spectrum Analyzer | 3-7 |
| Connecting the DC Amplifiers to the RF Cable Assembly | 3-9 |
| System Functional Tests | 3-10 |
| Test Set Verification Description | 3-10 |
| Procedure | 3-12 |
| Displayed Average Noise Level (DANL) Description | 3-15 |
| Part 1, 1 to 18 GHz | 3-15 |
| Part 2, 18 to 40 GHz | 3-16 |
| Equipment Required | 3-16 |
| Procedure | 3-17 |
| Part 1: 1 to 18 GHz | 3-17 |
| Part 2: 18 to 40 GHz | 3-19 |
| 4. Test Set Hardware Configurations | |
| 1 to 18 GHz Configuration | 4-1 |
| 18 to 26.5 GHz Configuration | 4-4 |
| 26.5 to 40 GHz Configuration | 4-6 |
| Cable and Connector Care | 4-7 |
| Connection Procedure | 4-7 |
| Disconnection Procedure | 4-8 |
| Handling and Storage | 4-8 |

| | |
|--|------|
| 5. System Interface | |
| DLP Softkey Menu | 5-2 |
| HP 84125C System Softkey Reference | 5-3 |
| 1GHz to 18GHz | 5-3 |
| 1.5GHz to 18GHz | 5-4 |
| 3.5GHz to 18GHz | 5-4 |
| 8.25GHz to 18GHz | 5-4 |
| 18GHz to 26.5 GHz | 5-5 |
| 26.5 GHz to 40GHz | 5-5 |
| Add to Mkr List | 5-5 |
| ADJUST LIMIT | 5-6 |
| CLEAR MKR LIST | 5-6 |
| COPY DISPLAY | 5-6 |
| HIGHEST PEAK | 5-6 |
| HP84125C Config | 5-6 |
| LIM LINE ON OFF | 5-7 |
| MARKER dB μ V/m | 5-7 |
| MAX HOLD ON OFF | 5-8 |
| MKR LIM ON OFF | 5-8 |
| NEXT PEAK | 5-8 |
| NEXT LT PEAK | 5-9 |
| NEXT RT PEAK | 5-9 |
| PRINT DISPLAY | 5-9 |
| PRINT MKR LIST | 5-9 |
| SAVE MKR #1 - #9 | 5-10 |
| SELECT LINEAR | 5-10 |
| SELECT LOG | 5-10 |
| SERVICE | 5-11 |
| TIMEDATE ON OFF | 5-11 |
| VIEW MKR LIST | 5-11 |
| 6. Making Measurements | |
| Configuring the Test Set | 6-2 |
| Setting Up the HP 8564E Spectrum Analyzer | 6-3 |
| Making the Measurement Using Peak Detection | 6-3 |
| Making a Measurement Using Average Detection | 6-4 |

| | |
|---|------|
| 7. Using the HP 84125C Utility | |
| Personal Computer Requirements | 7-2 |
| Minimum PC Requirements | 7-2 |
| Setting Up the HP-IB or GPIB Interface | 7-2 |
| Setting Up HP-IB Interface for Windows 3.1 | 7-2 |
| Hardware Installation | 7-2 |
| Software Installation | 7-3 |
| Setting Up HP-IB Interface for Windows 95 | 7-3 |
| Hardware Installation | 7-3 |
| Software Installation | 7-3 |
| Hardware Verification | 7-4 |
| Setting Up HP-IB Interface for Windows NT 4.0 | 7-4 |
| Hardware Installation (HP 82341C) | 7-4 |
| Software Installation | 7-4 |
| Hardware Verification (HP 82341C) | 7-5 |
| Setting Up AT-GPIB for Windows 3.1 | 7-5 |
| Hardware Setup and Installation | 7-5 |
| Software Installation | 7-6 |
| Software Setup | 7-6 |
| Hardware Verification | 7-6 |
| Setting Up AT-GPIB/TNT for Windows 95 | 7-7 |
| Software Installation | 7-7 |
| Hardware Configuration | 7-7 |
| Hardware Installation | 7-8 |
| Hardware Verification | 7-8 |
| Setting Up AT-GPIB/TNT for Windows NT 4.0 | 7-8 |
| Software Installation | 7-8 |
| Hardware Setup and Installation | 7-8 |
| Software Setup | 7-9 |
| Hardware Verification AT-GPIB/TNT | 7-9 |
| Installing the HP 84125C Download Utility on Your | |
| Personal Computer | 7-10 |
| Downloading the DLP into the Analyzer | 7-10 |
| File Menu | 7-10 |
| Print Factors | 7-10 |
| Exit | 7-10 |
| Edit Menu | 7-11 |
| Antenna Factors | 7-11 |
| Antenna Correction Factors Window | 7-11 |
| Antenna Data Area | 7-11 |
| Edit Area | 7-11 |
| Enter Point Button | 7-11 |
| Del Point Button | 7-11 |
| Add Point Button | 7-12 |
| Save Button | 7-12 |
| Exit Button | 7-12 |
| GPIB Configuration Window | 7-12 |
| GPIB Interface Card Selection Area | 7-12 |
| National GPIB/HPIB Address Area | 7-12 |
| Done Button | 7-13 |

| | |
|--|-----|
| 8. Customer Support | |
| If You Have a Problem | 8-1 |
| Calibration Information | 8-2 |
| Replaceable Parts | 8-2 |
| Returning the HP 84125C System for Calibration or Service | 8-3 |
| Packaging the HP 84125C System for Shipment | 8-3 |
| Hewlett-Packard Sales and Service Offices | 8-4 |
| A. Amplitude Accuracy | |
| Spectrum Analyzer Uncertainties | A-1 |
| HP 84125C Test-Set Uncertainties | A-2 |

Index

Figures

| | |
|--|------|
| 2-1. HP 84125C System Dimensions | 2-4 |
| 2-2. Typical Sensitivity from 1 to 18 GHz | 2-5 |
| 2-3. Typical Sensitivity from 18 to 26.5 GHz | 2-5 |
| 2-4. Typical Sensitivity from 26.5 to 40 GHz | 2-6 |
| 2-5. Declaration of Conformity | 2-8 |
| 3-1. Spectrum Analyzer Installation | 3-5 |
| 3-2. Front view of the Spectrum Analyzer | 3-7 |
| 3-3. Strain Relief Installation | 3-8 |
| 3-4. DC Amplifiers Cable Routing | 3-9 |
| 3-5. Reference Point Setup | 3-13 |
| 3-6. System Gain Verification | 3-14 |
| 3-7. DANL Measurement Setup, 1 to 18 GHz | 3-17 |
| 3-8. DANL Measurement Setup, 18 to 40 GHz | 3-19 |
| 4-1. Test Set Diagram | 4-1 |
| 4-2. 1 to 18 GHz Test-Set Configuration (top view) | 4-2 |
| 4-3. 18 to 26.5 GHz Test-Set Configuration (side view) | 4-4 |
| 4-4. 26.5 to 40 GHz Test-Set Configuration (side view) | 4-6 |
| 5-1. DLP softkey menu | 5-2 |
| 8-1. Component Location Diagram | 8-3 |

Tables

| | |
|---|------|
| 3-1. HP 84125C System Accessories | 3-2 |
| 3-2. Recommended Test Equipment and Accessories | 3-11 |
| 3-3. Hardware Configurations | 3-11 |
| 3-4. Correction Data Files | 3-12 |
| 3-5. Test Set Verification | 3-15 |
| 3-6. Recommended Test Equipment and Accessories | 3-16 |
| 3-7. Displayed Average Noise Level | 3-21 |
| 8-1. Replaceable Parts | 8-2 |
| 8-2. HP Sales and Service Offices | 8-5 |
| A-1. HP 84125C System Uncertainties | A-4 |

Product Description

The HP 84125C microwave EMI measurement test system is designed to measure the radiated energy from an unintentional or intentional radiator such as a transmitter or transceiver. It provides a system level solution to make measurements above 1 GHz. The HP 84125C system is designed to test products for EMI compliance to current FCC regulations governing emissions and measuring to current ETSI and CISPR regulations in the same frequency band.

The system is integrated into a portable instrument cart for easy transport to and from the test location. There are two major components of the system: a hand-held, tripod-mountable or antenna mast-mountable test set and the spectrum analyzer mounted on an instrument cart. The test set contains two low noise amplifiers, high-pass filters, antenna, and interconnecting cables. A three-meter RF cable assembly connects the test set to the spectrum analyzer and allows the test set to be moved around without moving the instrument cart. The RF cable assembly contains a rugged, low loss, high frequency cable and two DC power cables for the amplifiers.

Each system is calibrated by Hewlett-Packard before shipment. The calibration data consists of amplifier gain, cable loss, filter response, and antenna factors. The data is then stored into data correction tables which are loaded into the spectrum analyzer memory for easy recall during each measurement band.

The calibration data is also stored on a 3.5 inch floppy disk during factory calibration of the HP 84125C system and is shipped with each HP 84125C system. The floppy disk contains the amplitude correction factors for the test set (that is, amplifier gain, cable loss, and filter response) and the antenna. In addition, the disk also contains a MS-Windows utility that allows you to restore calibration data and modify antenna data if needed.

To combine the functionality of the HP 8564E spectrum analyzer and the test set, a downloadable program (DLP) has been provided. The DLP provides the system softkeys that set the parameters for making an EMI measurement. Hardware configurations can be selected enabling you to test the harmonic frequencies of your equipment under test (EUT) while filtering out the fundamental frequencies. The DLP uses correction data to account for gain\losses due to the antenna, cables, amplifiers, and filters.

Measurement Overview

The HP 84125C microwave EMI measurement test system may be used for a variety of measurements. To assure the best, most accurate measurements of your product, you should read and review the required product regulations. The following is a brief description of how to use the system to test a product to the FCC Part 15 regulation. A detailed measurement example for measuring an intentional radiator has been provided in Chapter 6.

Current FCC regulations specify that harmonic emissions measured above 1 GHz on wireless transmitters should be below $54 \text{ dB}\mu\text{V/m}$ using average detection at a distance of 3 meters. At higher frequencies, cable loss and antenna factors bring the inherent system noise level close to the regulatory limit. To improve the signal-to-noise ratio, the FCC allows positioning the measuring antenna at a distance closer than 3 meters. The correction to be applied is described in FCC, Part 15.31 (f)(1) which states:

“At frequencies equal to or above 30 MHz, measurements may be performed at a distance other than what is specified provided: measurements are not made in the near field; and, it can be demonstrated that the signal levels needed to be measured at the distance employed can be detected by the measuring equipment. Measurements shall not be performed at a distance greater than 30 meters unless it can be further demonstrated that measurements at a distance of 30 meters or less are impractical. When performing measurements at a distance other than what is specified, the results shall be extrapolated to the specified distance using an inverse linear distance extrapolation factor (20 dB/decade).”

This would translate to measuring to a limit of approximately $64 \text{ dB}\mu\text{V/m}$ at a distance of 1 meter. Therefore, we recommend that you first make a measurement at a distance of 1 meter to the $64 \text{ dB}\mu\text{V/m}$ limit line with peak detection. Using a 1 meter measurement will improve the signal-to-noise ratio making it easier to detect emissions. Signals with a peak value above the $64 \text{ dB}\mu\text{V/m}$ limit line will need to be remeasured using average detection.

Specifications and Characteristics

This chapter contains specifications, characteristics, and typical performance for the HP 84125C system.

Definition of Terms

Specifications describe warranted performance which is traceable to the National Bureau of Standards (NIST).

Characteristics describe non-warranted performance derived during the design phase of the system and is not verified on a continuing basis.

Typical Performance is non-warranted, but indicates performance which most units will exhibit.

| | |
|-------------------------------------|-------------|
| Frequency Range HP 84125C | 1 to 40 GHz |
|-------------------------------------|-------------|

| Spectrum Analyzer Displayed Average Noise Level (Measured at test-set input with 1 MHz RBW) ¹ | Specification | Typical |
|--|----------------------|----------------|
| 1 to 18 GHz | 6 dB μ V | -3 dB μ V |
| 18 to 26.5 GHz | 6 dB μ V | -3 dB μ V |
| 26.5 to 40 GHz | 9 dB μ V | 0 dB μ V |

¹ For use with the through cable or the correct high-pass filter for the selected frequency range

Limit to Noise Ratio / Sensitivity (Characteristic)

>6 dB (at 64 dB μ V/m)

| | |
|--|------------|
| Test Set (Includes amplifiers, filter, and RF cable assembly.) | |
| Calibration Data Uncertainty | ±0.9 dB |
| Flatness Uncertainty (Characteristic) | ±1.7 dB |
| Test-Set Repeatability (Characteristic) ¹ | ±0.7 dB |
| Maximum Temperature Drift (Characteristic) ² | ±1.5 dB |
| Input VSWR (Characteristic) | |
| 1 to 18 GHz | 3.2 to 1.0 |
| 18 to 40 GHz | 2.3 to 1.0 |

1 Includes cable flexure, amplifier aging, and connection repeatability.

2 The system is specified between 20°C and 30°C.

| Test-Set Filter Rejection (typical) | | | |
|--|-----------------|------------------------|----------------------|
| Frequency Range | Passband | 60 dB Rejection | Passband VSWR |
| 1 to 18 GHz | 1.5 to 18 GHz | ≤0.95 GHz | 2.1:1 |
| 1 to 18 GHz | 3.5 to 18 GHz | ≤2.5 GHz | 2.1:1 |
| 1 to 18 GHz | 8.25 to 18 GHz | ≤ 5.9 GHz | 2.3:1 |

HP 8564E Spectrum Analyzer Specifications and Characteristics

To guarantee the performance of the HP 84125C system, the HP 8564E spectrum analyzer must be operated under the following conditions:

- Five-minute warmup in ambient conditions
- Auto-coupled controls
- Digital trace display
- IF ADJ ON
- REF LVL CAL adjusted
- 1ST LO OUTPUT terminated in 50 ohms
- Two-year calibration cycle
- Environmental requirements met

Note

REF LVL CAL uses the CAL OUTPUT signal to calibrate the reference level. Internal temperature changes determine how often this adjustment should be performed. Amplitude temperature drift is a nominal 1 dB/10 °C. The nominal temperature variation within the instrument is 10 °C, most of which occurs during the first 30 minutes after power-on. Internal temperature equilibrium is reached after 2 hours of operation at a stable ambient temperature.

HP 8564E Spectrum Analyzer

Additional instrument specifications are described in *HP 8560 E-Series Calibration Guide*.

Antenna Specifications and Characteristics

| | | |
|--------------------------------|-------------------------------|--------------|
| Antenna Factor Accuracy | | |
| 1 to 18 GHz | HP 11966E | ± 2 dB |
| 18 to 26.5 GHz | HP part number 84125-80008 | ± 0.5 dB |
| 26.5 to 40 GHz | HP part number 84125-80001 | ± 0.5 dB |

| | |
|----------------------------------|------------|
| VSWR (characteristic) | |
| 1 to 18 GHz (HP 11966E) | 2.8 to 1.0 |
| 18 to 26.5 GHz (p/n 84125-80008) | 1.4 to 1.0 |
| 26.5 to 40 GHz (p/n 84125-80001) | 1.4 to 1.0 |

Third Order Intercept (characteristic)

>50 dB $_{\mu}$ V

| | | |
|-------------------------------|------------------------|----------|
| Weight | | |
| Test Set ¹ | 10.75 lb. ² | 23.7 kg |
| HP 84125C System ³ | 150 lb. | 330.8 kg |

¹ The weight includes the 1 to 18 GHz antenna horn.

² For an HP 84125C, with either the 18 to 26.5 GHz antenna horn or the 26.5 to 40 GHz antenna horn installed, the test-set weight is 7.5 lb or 16.5 kg.

³ Includes spectrum analyzer, instrument cart, and test set.

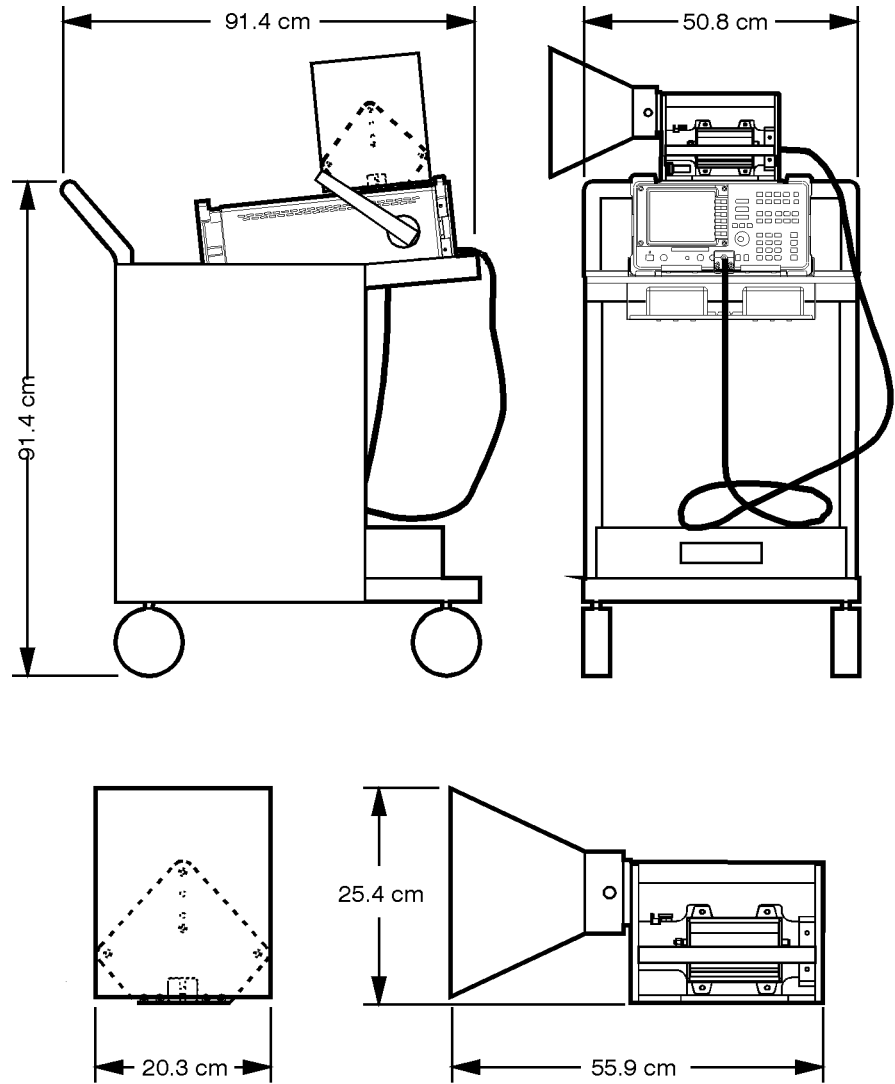

cartdim

Figure 2-1. HP 84125C System Dimensions

Typical Sensitivity for an HP 84125C System

Note

The values displayed by the HP 84125C system are the actual field strength of the emission (in $\text{dB}\mu\text{V}/\text{m}$), corrected for all system gains and losses including the antenna transducer factors.

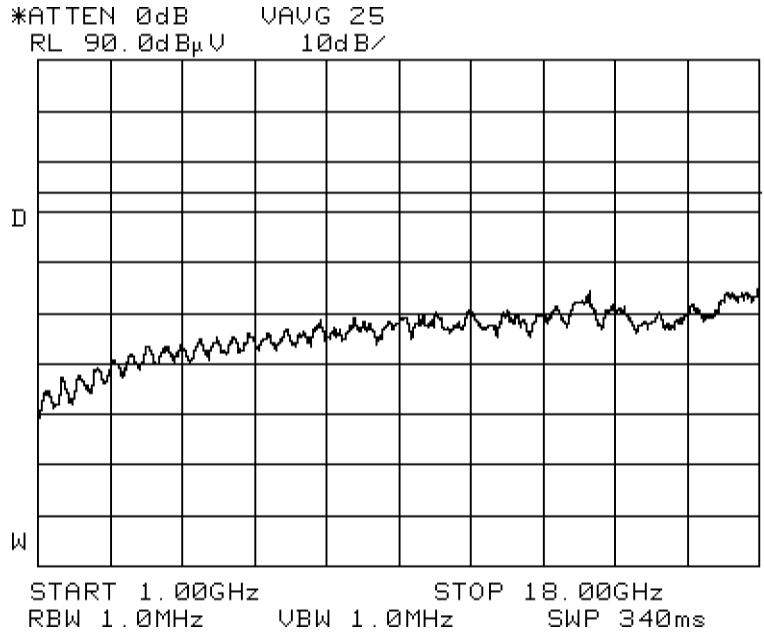

Figure 2-2. Typical Sensitivity from 1 to 18 GHz

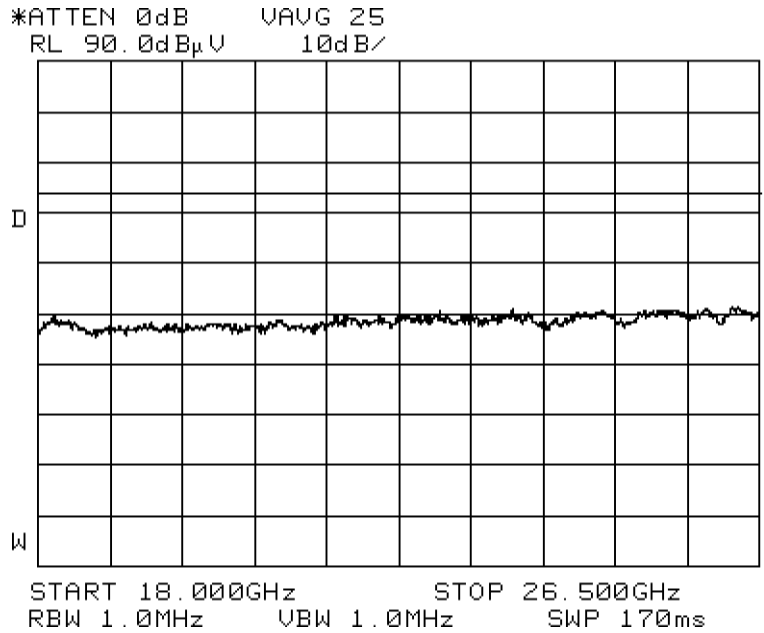

Figure 2-3. Typical Sensitivity from 18 to 26.5 GHz

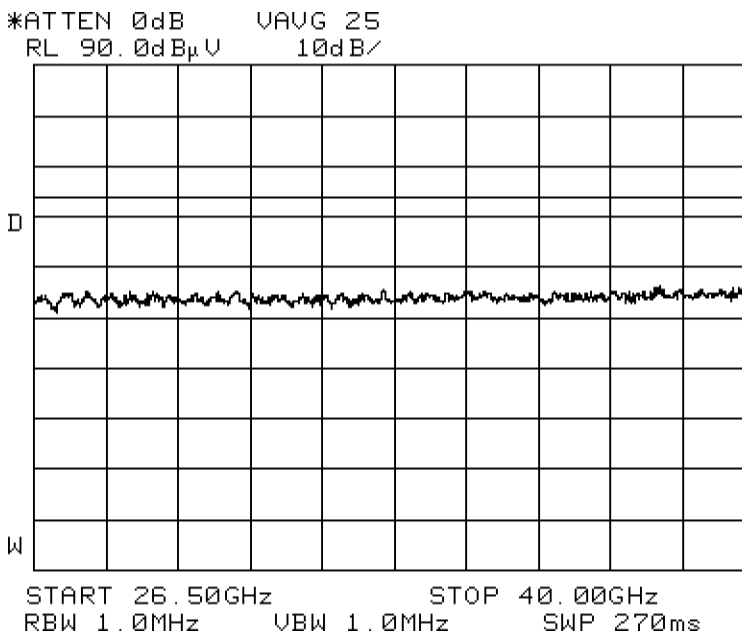

Figure 2-4. Typical Sensitivity from 26.5 to 40 GHz

Amplitude Accuracy

The table below shows the typical amplitude uncertainty for the HP 84125C system. The following conditions must be met to assure the amplitude accuracy of your system.

1. The HP 84125C system has been warmed up for 30 minutes or more at a stable temperature between 20 °C and 30 °C.
2. The spectrum analyzer meets the conditions listed in “HP 8564E Spectrum Analyzer Specifications and Characteristics”.
3. The HP 84125C system has valid calibration data.
4. The HP 84125C system has the proper correction data loaded for the selected hardware configuration.
5. The measurement is made with the spectrum analyzer in Linear Scale mode with a resolution bandwidth (RBW) of 1 MHz.
6. While the measurement is made, the spectrum analyzer reference level is kept at >56 dBμV/m when using the 1 to 18 GHz antenna, or 48 dBμV/m when using the 18 to 26.5 GHz antenna.
7. While the measurement is made, the measured signal is kept within the top five divisions (that is, the top half) of the display.

These conditions should work in most measurement situations. However, if conditions 5, 6, or 7 cannot be met, the measurement uncertainty should be calculated using the method detailed in Appendix A.

| Amplitude Accuracy (typical) | |
|-------------------------------------|--------|
| 1.0 to 2.9 GHz | 6.2 dB |
| 2.75 to 6.46 GHz | 6.4 dB |
| 6.46 to 13.2 GHz | 6.5 dB |
| 13.2 to 18.0 GHz | 6.8 dB |
| 18.0 to 22.0 GHz | 5.4 dB |
| 22.0 to 26.5 GHz | 5.6 dB |
| 26.5 to 40 GHz | 5.4 dB |

Declaration of Conformity

| DECLARATION OF CONFORMITY according to ISO/IEC Guide 22 and EN 45014 | |
|--|---|
| Manufacturer's Name: | Hewlett-Packard Co. |
| Manufacturer's Address: | Santa Rosa Systems Division 1400 Fountaingrove Parkway Santa Rosa, CA 95403-1799 USA |
| declares that the product | |
| Product Name: | Microwave EMI Measurement System |
| Model Number: | HP 84125C |
| Product Options: | This declaration covers all options of the above product. |
| conforms to the following Product specifications: | |
| Safety: EN 61010-1:1993 CAN/CSA-C22.2 No. 231 (Series M-89) | |
| EMC: CISPR 11:1990/EN 55011:1991 Group 1, Class A IEC 801-2:1984/EN 50082-1:1992 4 kV CD, 8 kV AD IEC 801-3:1984/EN 50082-1:1992 3 V/m, 27-500 MHz IEC 801-4:1988/EN 50082-1:1992 0.5 kV Sig. Lines, 1 kV Power Lines | |
| Supplementary Information: | |
| The product herewith complies with the requirements of the Low Voltage Directive 73/23/EEC and the EMC Directive 89/336/EEC and is marked accordingly. | |
| Santa Rosa, California, USA | 30 Oct. 1996  |
| John Hatt/Quality Engineering Manager | |
| European Contact: Your local Hewlett-Packard Sales and Service Office or Hewlett-Packard GmbH, Department HQ-TRE, Herrenberger Strasse 130, D-71034 Böblingen, Germany (FAX +49-7031-14-3143) | |

Figure 2-5. Declaration of Conformity

System Setup and Functional Tests

System Setup

The following procedure will assist you in setting up your HP 84125C system.

Initial Inspection

Your HP 84125C system is sent to you in three shipping containers. Inspect the shipping containers for damage. Use Table 3-1 to verify that the contents are complete. It is important that you retain the shipping containers for returning the system in one year for recalibration. See “Returning the HP 84125C System for Calibration or Service ” in Chapter 8 for more information.

Test Set Components

Table 3-1. HP 84125C System Accessories

| Description | HP Part Number | Comments |
|--|----------------|--|
| System Rack Box (largest carton) | | |
| Testmobile Instrument Cart | HP 1182A | Shipped assembled except for the handle and casters. The handle and hardware are contained in a carton within the system rack carton. The casters and hardware are attached to the bottom of the cart. |
| Accessory carton includes: | | |
| #10 torx driver | 8710-1623 | |
| #15 torx driver | 8710-1622 | |
| 8-in lb, 5/16 inch torque wrench | 8710-1765 | |
| High-Pass Filter, 1.5 GHz | 84300-80037 | |
| High-Pass Filter, 3.5 GHz | 84300-80038 | |
| High-Pass Filter, 8.25 GHz | 84300-80039 | |
| Std. Gain Horn Antenna, 18 to 26.5 GHz | 84125-80008 | Includes EMCO 3160-09 manual |
| Std. Gain Horn Antenna, 26.5 to 40 GHz | 84125-80001 | Includes EMCO 3160-10 manual |
| Power Module | HP 92199E | |
| Cable, Type N (m) to SMA (f) | 84125-20043 | |
| Cable, 2.4 mm (m) to 2.92 mm (m) | 84125-20044 | |
| Adapter, SMA (m) to SMA (m) | 1250-1159 | Adapter is attached to W3 (84125-20043) and should remain in this configuration. |
| Double-Ridged Horn Antenna, 1 to 18 GHz | HP 11966E | Includes EMCO 3115 (HP 11966E) manual |
| Power Supplies | HP 87421A | Two, $\pm 12V_{DC}$, 25W |
| Power Cords | 8120-1396 | Four, 30-inch power cords; located in the cart drawer |
| Power Cord (system) | | The part number varies in accordance with plug type used in your country. |
| Read Me First Document | 84125-90002 | Attached to the top of the accessories carton |
| HP 84125C User's Guide | 84125-90010 | |
| HP 1182A Operating Instructions | N/A | Taped to the bottom of the cart with the casters |
| Hardware packet for installing the spectrum analyzer | N/A | Packet is taped to the top of the rack tray. |

Table 3-1. HP 84125C System Accessories (continued)

| Description | HP Part Number | Comments |
|--|----------------|---|
| Spectrum Analyzer Box (medium-sized carton) | | |
| Front Cover | 5063-0274 | Not used, appropriate cable is supplied with the system. |
| Mass Memory Module | HP 85620A | |
| BNC Cable, 23 cm (9in) | HP 10502A | |
| 4 mm Hex (Allen) Wrench | 8710-1755 | |
| Power Cord | | |
| Fuse, 5 A, 250 V (supplied in fuse holder) | | |
| Adapter, Type N (m) to BNC (f) | 1250-0780 | |
| Adapter, SMA (m) to BNC (f) | 1250-1200 | |
| Adapter, K (f) to 2.4 mm (f) | 1250-2187 | |
| Adapter, 2.4 mm (f) to 2.4 mm (f) | 1250-2188 | |
| Termination, 50 Ω SMA (m) | 1810-0118 | |
| Test Set Box (smallest carton) | | |
| Test Set | | Includes amplifiers and appropriate cabling |
| Through Line | 84125-20019 | Contains the DLP with system correction factors and HP 84125C download utility. |
| Cable, 2.92, (k) (m) to 2.4 (m) | 84125-20042 | |
| HP 84125C Utility Disk | N/A | |

Installing the HP 84125C System

The following procedure will assist you with installing your HP 84125C system.

Assembling the Test Mobile Instrument Cart

1. From the largest carton, carefully remove the cart from its shipping container and the items contained in the space between the drawer and the upper shelf of the cart.

Note

The instrument strap will not be used for this installation.

2. Assemble the casters (that is, wheels) and the cart handle to the cart as shown in the *HP 1182A Testmobile Instrument Cart and Accessories Operating Guide*.

Installing the Spectrum Analyzer

Refer to Figure 3-1 to assist you with the following procedure.

1. Remove the spectrum analyzer from the medium-sized carton.
2. Remove the packet of hardware from the top shelf of the cart. The hardware will be used to assemble the system.
3. To attach the spectrum analyzer onto the metal bracket on top of the shelf:
 - a. Center the analyzer over the bracket with the front end of the analyzer tilted upwards.

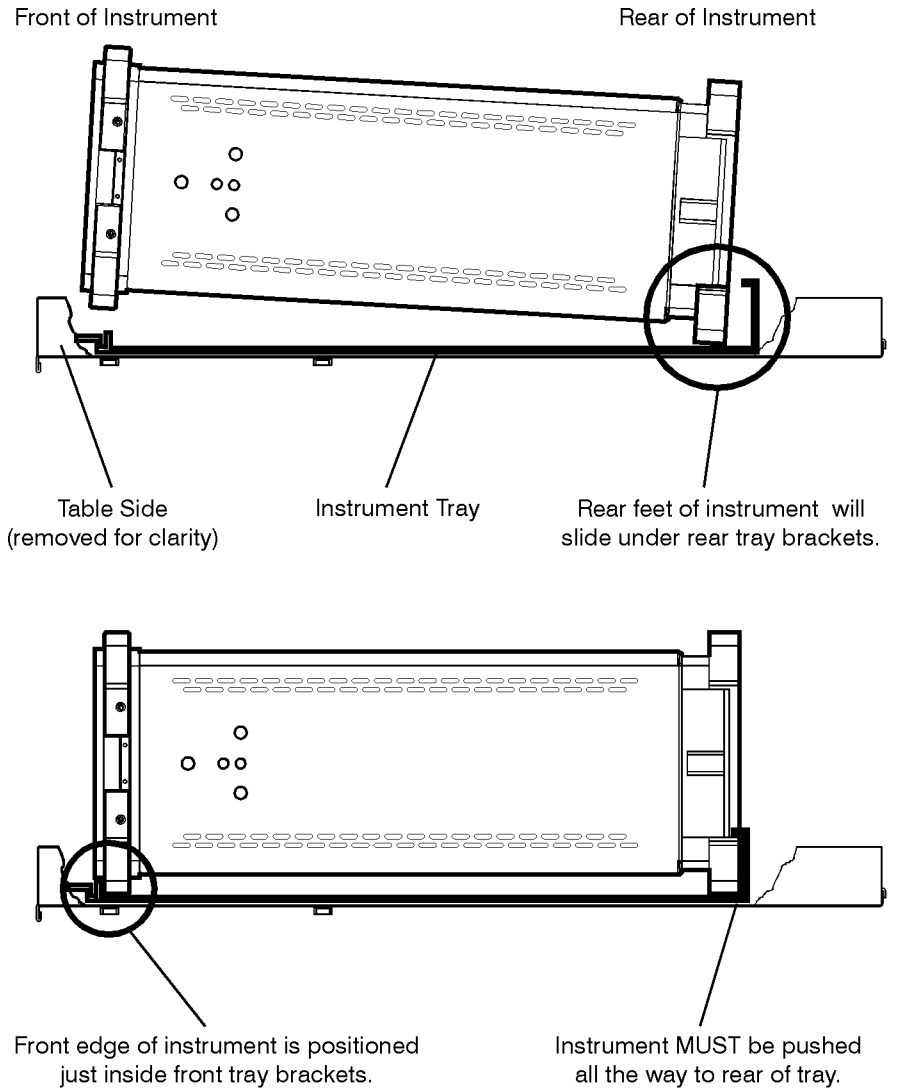

intotray

Figure 3-1. Spectrum Analyzer Installation

- b. Slide the rubberized bumpers on the back of the analyzer under the folded tabs on the back of the bracket.
- c. Lower the front of the analyzer into the bracket so that the front lower bumpers fit behind the front tabs of the bracket.
4. Position the analyzer clamps as shown in Figure 3-2 and loosely attach with four 4.0 mm X 16 mm screws.
5. Align the front edge of the clamp with the front edge of the bracket then tighten the hold-down screws.

Attaching the Power Module and Power Cords

1. Attach the power cord module (found in the accessories carton) to the rear-upper cart support. Use the metal posts located on the far right-hand side of the cart when viewed from the rear of the cart. The power cord module is grooved to slip over the metal posts.
2. Plug the power cord into the power module for the two amplifier power supplies (located on the bottom of the tiltable shelf).
3. Plug in the spectrum analyzer using one of the 30-inch power cords.
4. Attach the 8-foot long power cord supplied with the system to the power cord module.

CAUTION

Notice that the input end of this cable is specific to the country receiving the system. Before connecting the system to a power source, make sure that the spectrum analyzer line module is configured for the proper voltage requirements. Refer to Chapter 9 of the *HP 8560 E-Series Spectrum Analyzer User's Guide* for complete instructions.

Installing the Accessories and Test Set in the System

1. Open the drawer of the cart and remove all of the contents except the foam filler. Position the foam filler at the back of the drawer.
2. Remove the shipping foam with the accessories from the accessory carton and place it in the front of the drawer. This is a convenient place to store the system hardware.
3. Remove the test set with its attached three-meter RF cable assembly from the smallest carton and place it on top of the spectrum analyzer. Position the analyzer handle so that it rests against the back of the analyzer.

Note

Since the system functional tests require the RF cable assembly to be removed from the INPUT 50 Ω of the analyzer, you may elect to perform the system functional tests at this time. Additional equipment and accessories will be required to perform these tests. Refer to "System Functional Tests" later in this chapter.

Connecting the RF Cable Assembly to the Spectrum Analyzer

Refer to Figure 3-2 for the following procedure.

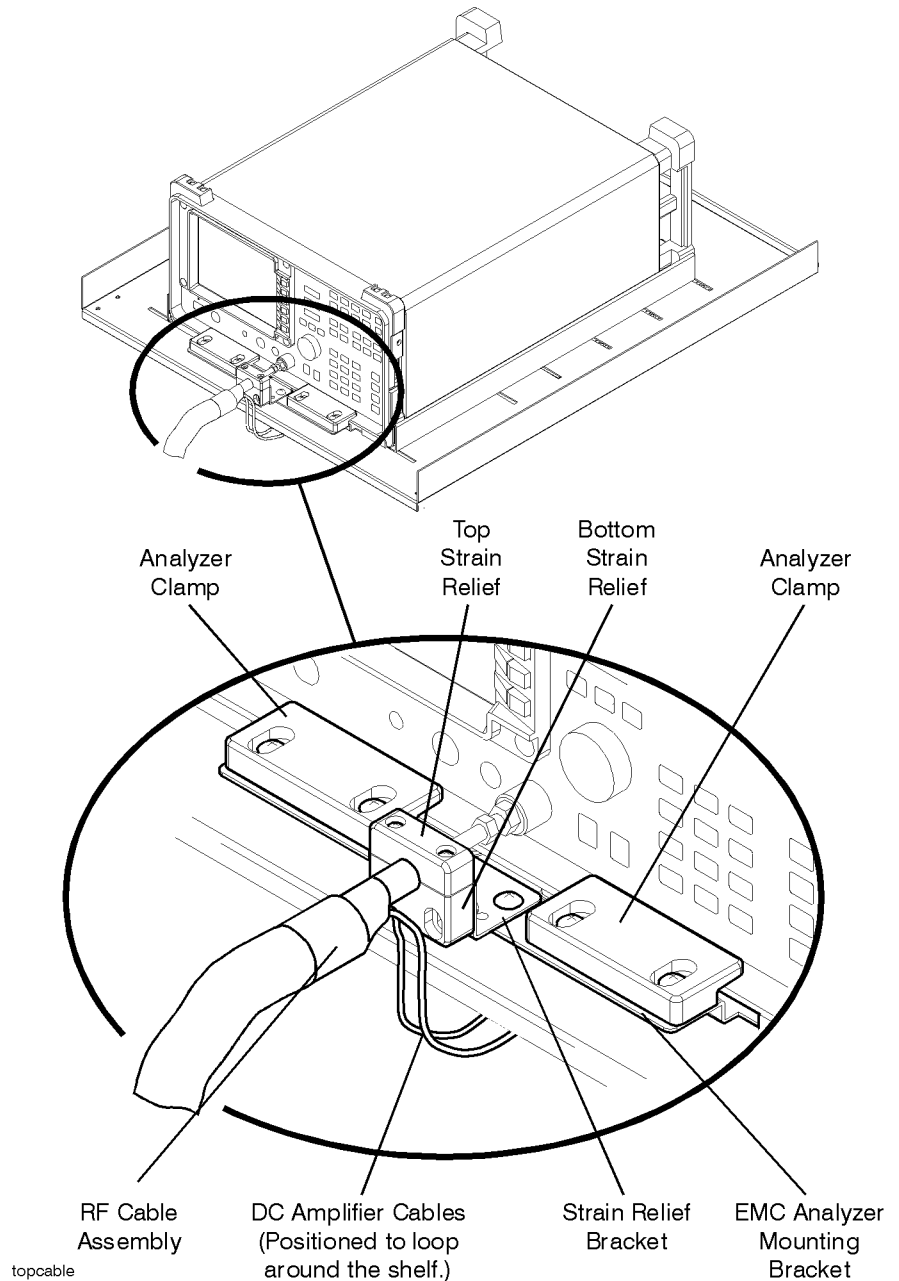

Figure 3-2. Front view of the Spectrum Analyzer

1. Use a #15 torx driver and two 4.0 mm X 12.0 mm torx screws to attach the strain-relief support bracket to the spectrum analyzer mounting bracket. Notice that the strain-relief bracket has four holes in the bottom surface. Use the two holes closest to the strain relief.

Note

Be sure to use the correct adapter when connecting the RF cable assembly to the spectrum analyzer.

2. Connect the RF cable assembly from the test set to the spectrum analyzer INPUT 50Ω using the 2.4 mm (f) to (f) RF adapter (part number 1250-2188) supplied with the spectrum analyzer. Before torquing the connector, make sure the two DC power cables are facing toward the bottom of the cart. Use the torque wrench to torque the connector to 8-inch pounds.
3. The RF cable strain relief has a top and bottom section. The bottom section has two slotted holes in one surface. Use a #10 torx driver and two 3.5 mm X 16.0 mm screws to attach the bottom section to the strain-relief bracket. Tighten the screws just enough to hold the bottom strain relief against the bracket surface.
4. Use a #10 torx driver and two 3.0 mm X 14.0 mm screws to attach the top section of the strain relief to the bottom section of the strain relief. Tighten the screws to properly secure the RF cable.

CAUTION

Be sure to leave an equidistant gap (that is, spacing) between the top and bottom portion of the strain relief. This will ensure that the maximum amount of strain relief is supplied to the RF cable assembly. Refer to Figure 3-3 for proper strain-relief installation.

5. Tighten the bottom strain relief screws.

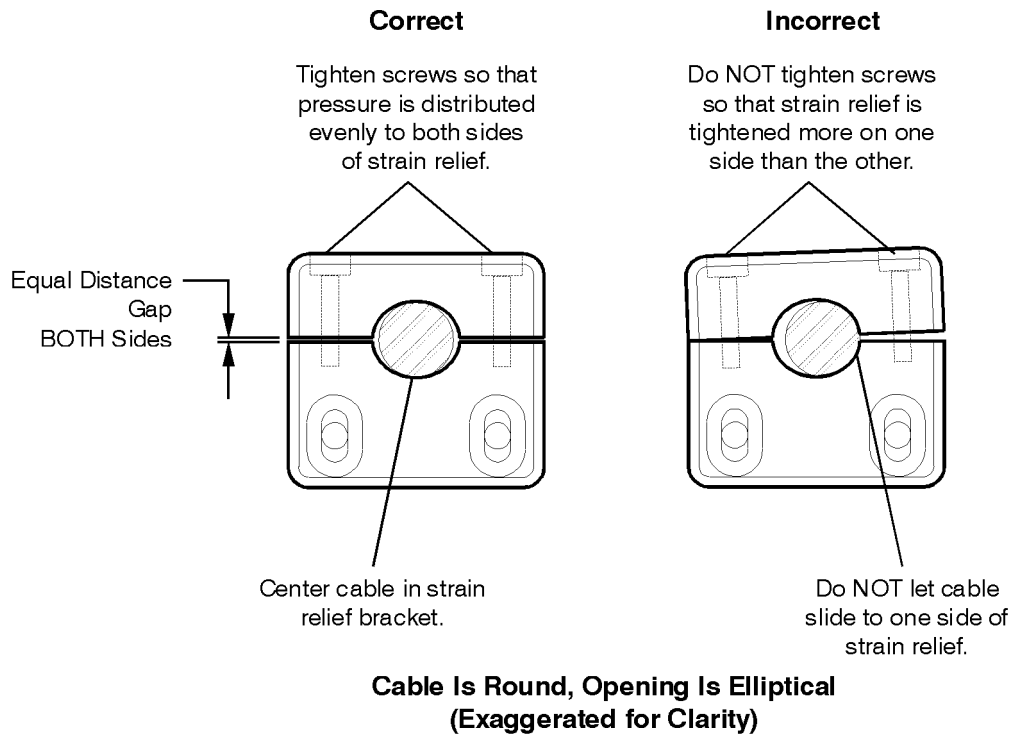

strain

Figure 3-3. Strain Relief Installation

Connecting the DC Amplifiers to the RF Cable Assembly

Refer to Figure 3-4 for the following procedure.

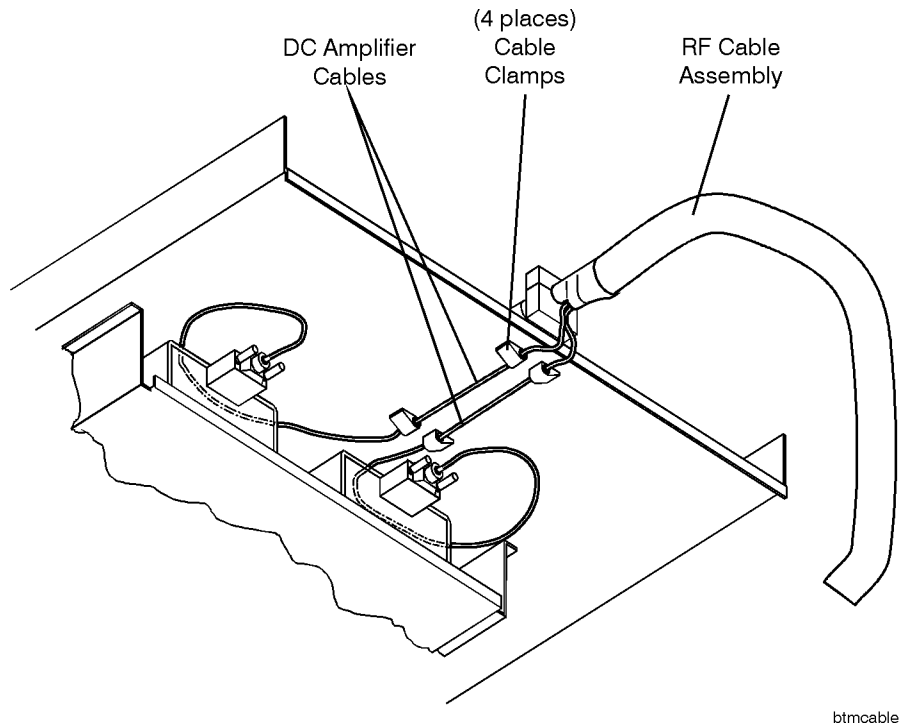

Figure 3-4. DC Amplifiers Cable Routing

1. Locate the two DC amplifier cables where they separate from the RF cable assembly. Position the DC amplifier cables so that they loop around the edge of the shelf. Clamp the cables to the bottom of the shelf using four 4.0 mm screws and four cable clamps.

The loop should be large enough that normal cable flexure will not cause the DC cables to rub the shelf edge. Any excess cable length should be routed above the two amplifier power supplies mounted on the bottom of the shelf.

2. Connect the two DC amplifier cables to the two power supplies.
3. Configure the test set with the required filters, antenna, and cables for your testing needs. Refer to Chapter 4 for more information on test set configurations.

System Functional Tests

The purpose of the system functional tests are to verify that the HP 84125C microwave EMI measurement test system is operating correctly. The test consists of two sections:

- Test Set Verification
- Displayed Average Noise Level (DANL)

Test Set Verification Description

This test procedure instructs you to perform specific tests that will verify the functionality and performance of the system. Completion of these tests will verify that the:

- Downloadable program (DLP) is loaded and operational
- Amplifiers, cables, and filters are operating properly (that is, measures the gain of the test set)
- Proper correction factors are loaded into the spectrum analyzer

The correction factors for the test set and antenna are deactivated in the spectrum analyzer. The output of the synthesized sweeper is fed through a 10 dB attenuator directly into the input of the spectrum analyzer, bypassing the test set (see Figure 3-5). The synthesized sweeper power level is adjusted for a -65 dBm signal of the spectrum analyzer display. The power level is then recorded.

The test set is then connected to the input of the spectrum analyzer with the correction factors turned off. The spectrum analyzer reference level must be changed to account for the gain of the amplifiers in the test set. The output of the synthesized sweeper is fed through a 10 dB attenuator directly into the test set (see Figure 3-6). The displayed amplitude on the spectrum analyzer is recorded. The difference between the recorded value and -65 dBm is the gain of the test set. The resultant gain value is recorded and compared to the actual test set gain value.

For each new synthesizer sweeper frequency and spectrum analyzer center frequency setting, the above procedure is repeated.

Note

These tests are intended for basic system verification purposes only. The test methods being used result in a higher level of measurement uncertainty. Therefore, the measurement uncertainty factor has been increased.

**Table 3-2.
Recommended Test Equipment and Accessories**

| Equipment and Accessories | Critical Specifications for Equipment Substitution | Recommended Model |
|---------------------------|--|------------------------|
| Synthesized Sweeper | Frequency Range: 10 MHz to 40 GHz | HP 83640B |
| 10 dB Attenuator | 2.4 mm (m) to (f) Frequency Range: 40 GHz | HP 8490D Option 010 |
| Adapter | 2.4 mm (m) to 2.4 mm (f) | HP 11901D |
| Adapter | 2.4 mm (f) to 2.4 mm (f) | 1250-2188 |
| Adapter | Type N (m) to APC 3.5 (f) | 1250-1744 |
| Cable | Connectors: 2.4 mm (m) (both ends) Frequency Range: 1 to 40 GHz 24 inches long | 84125-90042 |

The following test procedure measures the test set gain for one frequency point. This procedure must be repeated if the frequency or hardware configuration is changed.

The gain of the test set is measured over defined frequency ranges with the test set configured with the appropriate cables and filter. The following table summarizes those hardware configurations. See Figure 3-5 and Figure 3-6 for hardware locations.

Table 3-3. Hardware Configurations

| Configuration | Input (Cable #) | Filter or through line | Amplifier Input (Cable #) | Test Frequency (GHz) |
|---------------|-----------------|------------------------|---------------------------|----------------------|
| Band 0 | W3 | W9 | W1/W2 | 1, 18 |
| Band 1 | W3 | 84300-80037 | W1/W2 | 1.5, 18 |
| Band 2 | W3 | 84300-80038 | W1/W2 | 3.5, 18 |
| Band 3 | W3 | 84300-80039 | W1/W2 | 8.25, 18 |
| Band 4 | W4 | none | W2 | 18, 26.5 |
| Band 5 | W4 | none | W2 | 26.5, 40 |

HP 84125C download utility disk is generated during factory calibration of the HP 84125C system and is shipped with each system and is specific to that system. The disk contains amplitude correction factors for the test set and the three available antennas.

The download utility disk contains the DLP and a MS-Windows utility that allows you to restore calibration data or modify antenna data if needed. The utility combines the test set gain factors with the antenna correction factors and down-loads the data (via GPIB) into the spectrum analyzer's AMPCOR registers. The correction factors for

your system were loaded into the spectrum analyzer at the factory or Hewlett-Packard Service Center.

To view the test set gain and antenna correction factor data separately, you must use the HP 84125C utility disk provided with the HP 84125C system. The following files can be found on the utility disk:

CAUTION

The test set gain correction factor files are for viewing purposes only. Since these files are *not* write protected, any changes inadvertently made to these correction factors will result in an uncalibrated system. Therefore a system calibration would need to be performed to ensure accurate measurements.

Table 3-4. Correction Data Files

| File Name | Frequency Range (GHz) |
|----------------------------|-----------------------|
| Antenna Correction Factors | |
| e3115.txt | 1 to 18 |
| e3160-09.txt | 18 to 26.5 |
| e3160-10.txt | 26.5 to 40 |
| Test Set Gain | |
| filter_0.txt | 1 to 18 Band 0 |
| filter_1.txt | 1.5 to 18 Band 1 |
| filter_2.txt | 3.5 to 18 Band 2 |
| filter_3.txt | 8.25 to 18 Band 3 |
| filter_4.txt | 18 to 26.5 Band 4 |
| filter_5.txt | 26.5 to 40 Band 5 |

Procedure

1. Insure that the spectrum analyzer meets the conditions listed in “HP 8564E Spectrum Analyzer Specifications and Characteristics” in Chapter 2.
2. Press **PRESET** on the synthesized sweeper then set the controls as follows:

| | |
|-------------|---|
| CW | 1 GHz (or one of the other Test Set Frequencies in Table 3-5) |
| Power Level | –60 dBm |

3. Connect the synthesized sweeper to the input of the spectrum analyzer using the cable and 10 dB fixed attenuator. Refer to Figure 3-5.

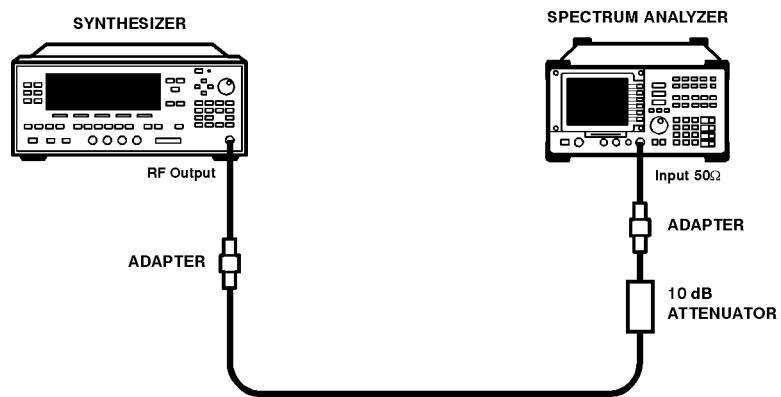

Figure 3-5. Reference Point Setup

4. Press **(Preset)** on the spectrum analyzer.
5. Change the spectrum analyzer settings by pressing the following keys:
 - a. **(SPAN)**, 20 **(MHz)**
 - b. **(FREQUENCY)**, **CENTER FREQ**, 1 **(GHz)** (or one of the other Test Set Frequencies in Table 3-5)
 - c. **(AMPLITUDE)**, **REF LVL** -55 **(dBm)** **ATTEN AUTO MAN**, 10 **(dB)**
 - d. **(BW)**, **VIDEO BW AUTO MAN**, 30 **(kHz)**
6. **For frequencies above 2.9 GHz only:**
 - a. **(PEAK SEARCH)**
 - b. **(AMPLITUDE)**, **MORE 1 OF 3**, **MORE 2 OF 3**, **PRESEL AUTO PK**
 Wait for the peaking message to disappear then press **(PEAK SEARCH)**.
7. Adjust the synthesized sweeper amplitude until the spectrum analyzer display indicates a level of -65 dBm.
8. Record the synthesizer output level in Table 3-5.

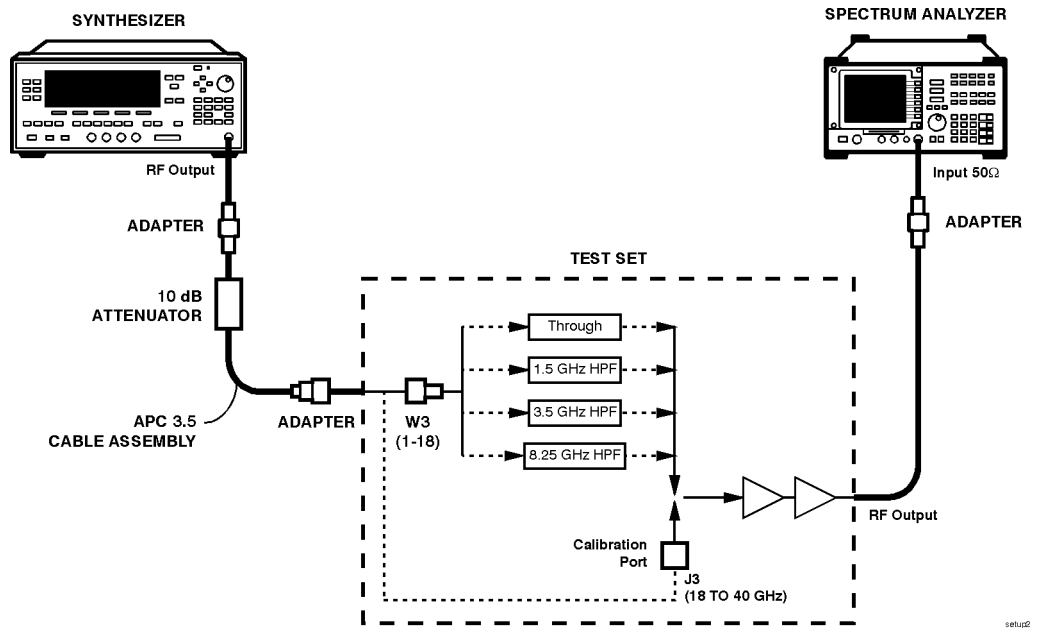

Figure 3-6. System Gain Verification

9. Disconnect the synthesized sweeper cable from the spectrum analyzer RF input (ensure the 10 dB attenuator remains on the end of the cable).
 10. Change the spectrum analyzer reference level setting by pressing, **AMPLITUDE**, **REF LVL**, **0 dBm**
 11. Connect the test set RF output cable to the spectrum analyzer RF input using the 2.4 (f) to (f) adapter. Refer to Figure 3-6.
 12. Connect the synthesized sweeper cable with 10 dB attenuator to the input of the test set.
 13. Press **PEAK SEARCH** on the spectrum analyzer and record the marker amplitude in Table 3-5.
 14. Calculate the gain of the test set by comparing the difference between -65 dBm and the level recorded in step 13. Record the measured test set gain in Table 3-5.
 15. Determine the factory test set gain correction factor for the configuration band selected by performing the following:
 - a. Press **MODULE**, **USER KEYS**, **HP84125C Config**
 - b. Select one of the six available configurations (see Configuration Band in Table 3-5) and ensure that the appropriate hardware is correct for the selected configuration. Refer to Figure 3-6.
- Once the configuration is loaded, press;
- c. **HP84125C Config**, **More**, **Service**

A screen will come up that displays the factory test set gain correction factors for the current band. Record these factors in Table 3-5.

16. Calculate the deviation by taking the difference between the measured test set gain (recorded in step 14) and the factory test set gain correction factor (recorded in step 15c). Record the deviation in Table 3-5.
17. The deviation should be ± 3.5 dB.
18. Repeat the above procedure, starting at step 5 for each test frequency and hardware configuration.

Table 3-5. Test Set Verification

| Configuration Band (GHz) | ¹ Test Set Frequencies (GHz) | Synthesizer Output Level (dBm) | Marker Amplitude (dB) | Measured Test Set Gain (dB) | Factory Test Set Gain (dB) | Deviation (dB) | Limits (dB) |
|--------------------------|---|--------------------------------|-----------------------|-----------------------------|----------------------------|----------------|-------------|
| 1 to 18 | 1 | | | | | | ± 3.5 |
| 1 to 18 | 18 | | | | | | ± 3.5 |
| 1.5 to 18 | 1.5 | | | | | | ± 3.5 |
| 1.5 to 18 | 18 | | | | | | ± 3.5 |
| 3.5 to 18 | 3.5 | | | | | | ± 3.5 |
| 3.5 to 18 | 18 | | | | | | ± 3.5 |
| 8.25 to 18 | 8.25 | | | | | | ± 3.5 |
| 8.25 to 18 | 18 | | | | | | ± 3.5 |
| 18 to 26.5 | 18 | | | | | | ± 3.5 |
| 18 to 26.5 | 26.5 | | | | | | ± 3.5 |
| 26.5 to 40 | 26.5 | | | | | | ± 3.5 |
| 26.5 to 40 | 40 | | | | | | ± 3.5 |

¹ The test frequencies listed are for convenience purposes. Any frequency from 1 to 40 GHz can be tested. However, you must ensure that the proper correction factors are used to calculate the deviation. Refer to Table 3-4.

Displayed Average Noise Level (DANL) Description

This test measures the displayed average noise level of the HP 84125C microwave EMI measurement test system.

The test set is connected to the input of the spectrum analyzer. The DLP is used to set up the initial spectrum analyzer settings and to load the correction factors for the complete test set. This includes the correction factors for the antenna (that is, the antenna factors) and correction factors for the amplifiers, cables, and filters.

The DANL test is performed in two parts:

Part 1, 1 to 18 GHz

Video averaging is activated and the displayed average noise level is measured in zero span at the selected frequency points. The antenna correction factor at the test frequency must be used to calculate the actual displayed average noise level. The antenna is not used for this test and is substituted by a 50 ohm termination.

Part 2, 18 to 40 GHz

The antenna correction factors above 18 GHz have minimal deviation. Therefore, the DANL measurement is performed across two frequency ranges (that is, 18 to 26.5 GHz and 26.5 to 40 GHz) compared to the single point method used in the 1 to 18 GHz range. Video averaging is activated and the spectrum analyzer display line function is used to record the amplitude value. A single antenna correction factor is used (that is, one for each antenna horn, 18 to 26.5 GHz and 26.5 to 40 GHz) to calculate the displayed average noise level for the entire frequency range. The antenna is bypassed for this test and the antenna cable is re-routed to a test port. A 50 ohm termination is attached to the test port (J1).

Note

Once the downloadable program (DLP) is loaded, the antenna correction factors can not be deactivated independently. Therefore, antenna correction factors must be used to calculate the correct displayed average noise level.

Equipment Required

Table 3-6. Recommended Test Equipment and Accessories

| Equipment and Accessories | Critical Specifications for Equipment Substitution | Recommended Model |
|---------------------------|---|-------------------|
| Adapter | APC 3.5 (f) to APC 3.5 (f) | 5061-5311 |
| Adapter | Type N (f) to APC 3.5 (f) | 1250-1745 |
| Adapter | 2.4 mm (m) to K-2.92 (m) | 1250-2187 |
| Termination, 50 Ω | Connector: APC 3.5 (m) Frequency Range: 1 to 26.5 GHz | HP 909D |
| Termination, 50 Ω | Connector: 2.4 mm (f) Frequency Range: DC to 50 GHz | HP 85138B |

- Procedure** ■ Ensure that the spectrum analyzer meets the conditions listed in “HP 8564E Spectrum Analyzer Specifications and Characteristics” in Chapter 2.

Part 1: 1 to 18 GHz

1. Connect equipment as shown in Figure 3-7.

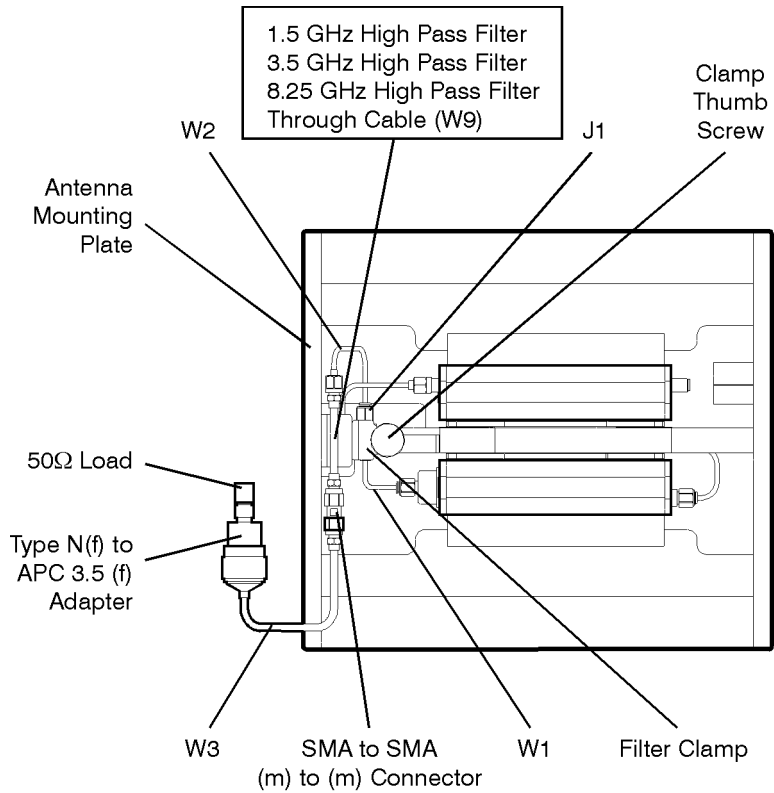

setup3

Figure 3-7. DANL Measurement Setup, 1 to 18 GHz

2. Set up the initial spectrum analyzer settings and load in all the correction factors for the system by activating the DLP as follows:
- Press **MODULE**, **USER KEYS**, **HP84125C Config**, **1GHz to 18GHz**.
 - Ensure that the test set hardware is correct for the configuration selected. There are different correction factors for each hardware configuration. Refer to Chapter 4 for proper test set hardware configuration.
 - Press **MORE**, **LIM LINE ON *OFF*** to turn the limit line off.
3. Change the initial analyzer settings by pressing the following keys:
- SPAN**, **ZERO SPAN**
 - AMPLITUDE**, **REF LVL**, **70 dBm** to set the reference level to 70 dB μ V.

- c. **[BW]**, VIDEO BW AUTO MAN with MAN underlined, 10 **[kHz]**
- d. **[TRACE]**, MORE 1 OF 3, VID AVG ON OFF with ON underlined, 10 **[Hz]**

Wait until “VAVG 10” is displayed at the top of the analyzer display. The analyzer will video average in ten sweeps.

- 4. Press **[DISPLAY]**, DSPL LIN ON OFF with ON underlined to activate the display line function.
- 5. Using the front-panel RPG knob, adjust the display line so that it is centered in the average trace noise. Record the display line amplitude in Table 3-7.
- 6. Determine the antenna correction factor at 9.5 GHz for your system by performing the following:
 - a. Insert the 3.5 inch floppy disk provided with the HP 84125C system into a personal computer (PC).
 - b. Open Windows File Manager, select the floppy disk drive (for example, drive A) and double-click on **e3115.txt**.
 - c. Scroll down the list of frequencies and correction factors until you find 9.5, xx.x. Where xx.x is the correction factor at 9.5 GHz. (For example, 9.5,39.8.)
 - d. Record the antenna correction factor for 9.5 GHz in Table 3-7.
- 7. To calculate the displayed average noise level, subtract the antenna correction factor recorded in the step 6d from the display line amplitude recorded in step 5. Record the DANL in Table 3-7. The specification is 6 dB μ V.
- 8. Repeat the above procedure to measure the displayed average noise level at a different frequency or hardware configuration.

Note

Ensure that the correct antenna factor is used when calculating the displayed average noise at a different frequency in step 7.

Part 2: 18 to 40 GHz

1. Connect equipment as shown in Figure 3-8.

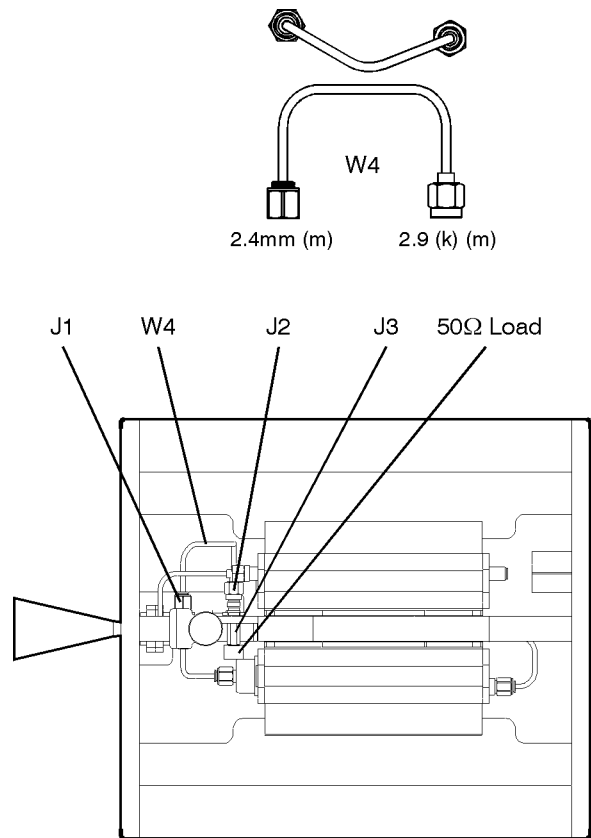

btop

Figure 3-8. DANL Measurement Setup, 18 to 40 GHz

2. Connect the W4 cable from J1 to the J2 connector.
3. Connect the 50 ohm termination to the J3 connector.
4. Set up the initial spectrum analyzer settings and load in all the correction factors for the system by activating the DLP as follows:
 - a. Press **MODULE**, **USER KEYS**, **HP84125C CONFIG**, **More**, **18GHz to 26.5GHz**.
 - b. Ensure that the test set hardware is correct for the configuration selected. There are different correction factors for each hardware configuration. Refer to Chapter 4 for proper test set hardware configuration.
 - c. Press **MORE**, **LIM LINE ON *OFF*** to turn the limit line off.
5. Change the analyzer settings by pressing the following keys:
 - a. **TRACE**, **MORE 1 OF 3**, **VID AVG ON OFF** with ON underlined, **10 Hz**

Wait until "VAVG 10" is displayed at the top of the analyzer display. The analyzer will video average on ten sweeps.

6. Press **DISPLAY**, **DSPL LIN ON OFF** with ON underlined to activate the display line function.
7. Using the front-panel RPG knob, adjust the display line so that it is centered in the average trace noise. Record the display line amplitude in Table 3-7.
8. Repeat the above procedure but substitute the following settings for step 4.
 - a. Press **MODULE**, **USER KEYS**, **HP84125C Config**, **More**, **26.5GHz to 40GHz**.
9. Calculate the displayed average noise level across the two frequency bands by subtracting the appropriate antenna correction factor from the display line amplitude recorded in step 7. Record the calculated DANL in Table 3-7. The specification is 6 dB μ V from 18 to 26.5 GHz and 9 dB μ V from 26.5 to 40 GHz.

Note

The antenna correction factors for the two high-frequency horn-antennas (the 18 to 26.5 GHz and the 26.5 to 40 GHz antennas) are very flat. Therefore, this test uses a single antenna correction factor (one for each high frequency band) to calculate the displayed average noise level.

If the displayed average noise level is close to or above the limit you can measure it at specific frequencies using the exact antenna correction factor as listed in the HP 84125C system utility. Determine the antenna correction factors for your system by performing the following:

1. Insert the 3.5 inch floppy disk provided with the HP 84125C system into a personal computer (PC).
 2. Open Windows File Manager and select the floppy disk drive (for example, drive A). Double-click on e3160-09.txt for frequencies from 18 to 26.5 GHz or, e3160-10.txt for frequencies from 26.5 to 40 GHz.
 3. Scroll down the list of frequencies and correction factors until you find the desired frequency. The first number is the frequency in GHz and the number following the comma is the antenna correction factor. For example, a listing of 22,40.33 means that at 22 GHz the antenna correction factor is 40.33 dB
 4. Record the actual antenna correction factor for the desired frequency in Table 3-7.
-

Table 3-7. Displayed Average Noise Level

| Frequency Range (GHz) | Display Line Amplitude (dBμV) | Antenna Correction Factor (dB) | Calculated DANL (dBμV) | Limit (dBμV) |
|----------------------------------|---|---|--|--|
| 1 to 18 | | ¹ | | 6 |
| 18 to 26.5 | | 40.3 | | 6 |
| 26.5 to 40 | | 43.5 | | 9 |

¹ The antenna correction factor is determined in Part 1, step 6 of the Displayed Average Noise Level Test.

Test Set Hardware Configurations

This chapter describes how to set up and configure your test set with the appropriate antenna and filters needed to make measurements over the entire frequency range of the HP 84125C system. When making measurements from 1 to 18 GHz, a high-pass filter can be installed. If testing an intentional radiator product, this helps to avoid an RF overload condition by filtering out the fundamental frequency. There are three filters supplied with the system: 1.5 GHz, 3.5 GHz, and 8.25 GHz. These filters provide 60 dB of rejection at the fundamental frequency. Measurement of harmonics above 18 GHz do not require the use of a high-pass filter; the 18 to 26.5 GHz and 26.5 to 40 GHz waveguide horn antennas serve as high-pass filters.

Figure 4-1 shows the possible antenna and filter configurations available.

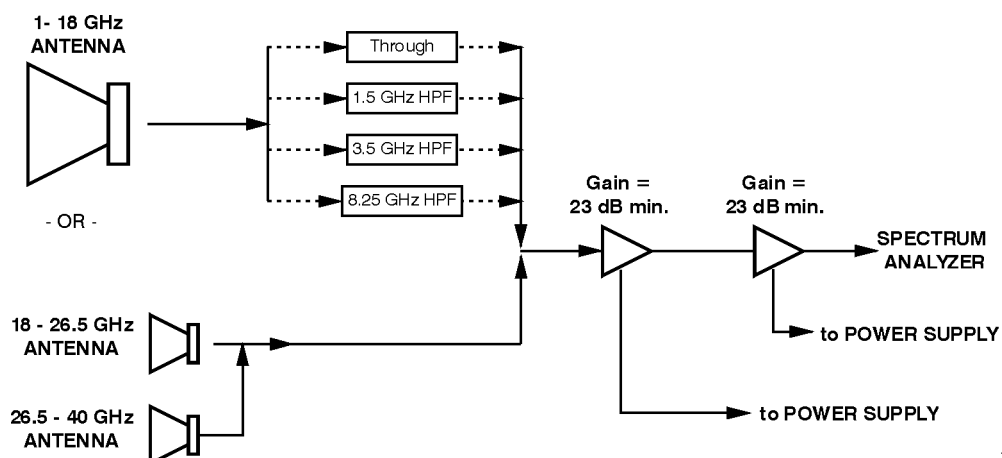

Figure 4-1. Test Set Diagram

1 to 18 GHz Configuration

Note

- If an antenna is already installed, you may need to remove the antenna and any associated cables or filters before installing another antenna.
- When performing the following antenna installation, only finger tighten connectors keeping all connections loose until the last step.
- To ensure good cable connections, refer to “Cable and Connector Care” found later in this chapter.

1. Attach the antenna (HP 11966E) to the front plate. Position the antenna so that the Type N connector on the test set is pointing to the right of the test set as viewed from the front. Use the 1/4 inch flat washer, the split lock washer, and the 1/4-20 hex nut supplied in the accessories box, to attach the antenna. See Figure 4-2 below.

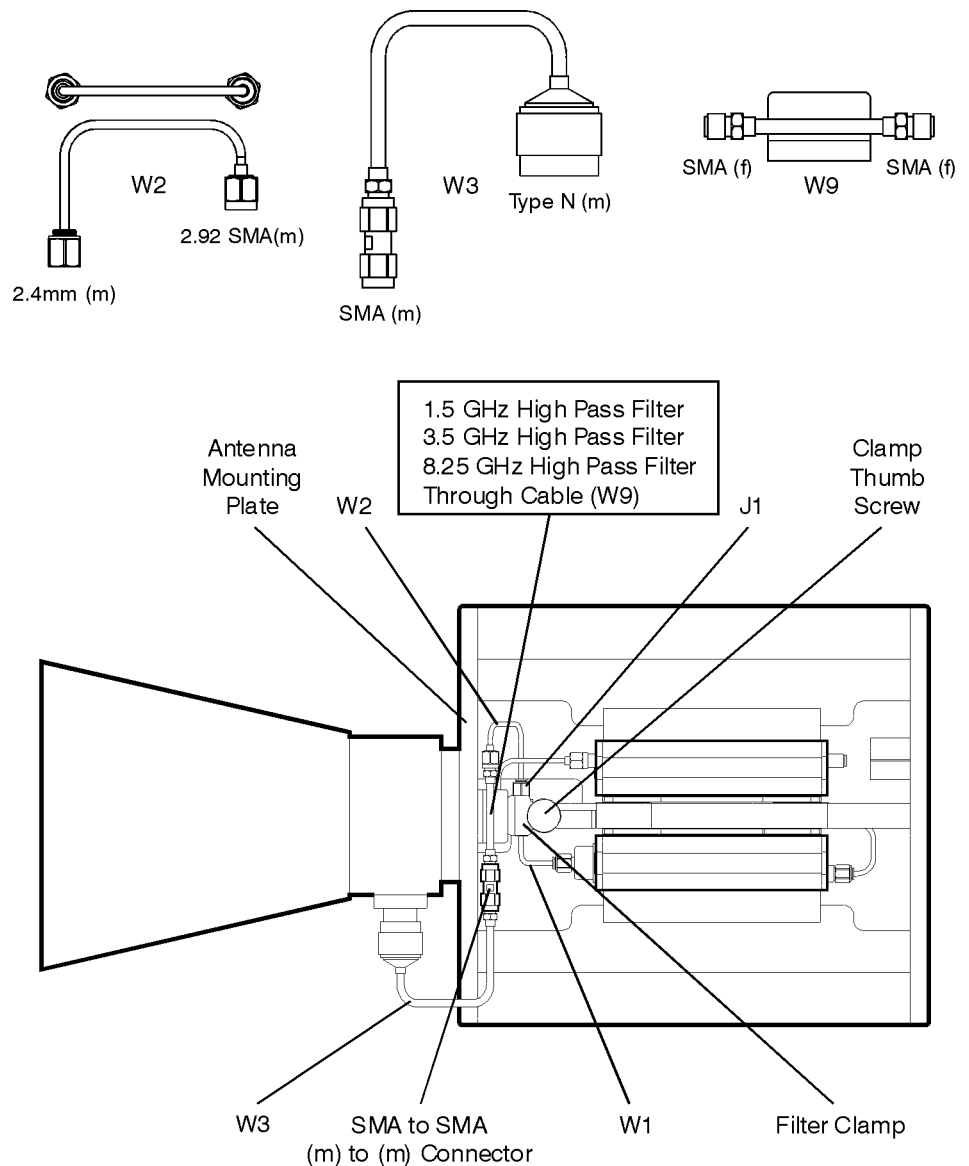

Note: Test set top handle has been removed to aid viewing.

aview

Figure 4-2. 1 to 18 GHz Test-Set Configuration (top view)

2. Loosely install the Type N connection of the W3 semirigid cable to the antenna. The cable will have an SMA (m) to (m) adapter installed on one end.
3. Select one of the three filters or the through cable and attach it to the SMA (m) to (m) adapter on the end of the W3 semirigid cable.

Position the filter or through cable in the space provided in front of the filter clamp. Push the filter clamp toward the filter while keeping the filter within the recessed area of the antenna mounting plate. When the filter is properly positioned, tighten the clamp thumb screw to secure the filter. You will need to use a 1/4 inch open-end wrench to hold the connector on the through cable while tightening the mating connector.

| Description | Part Number |
|---------------------------|--------------------|
| 1.5 GHz High Pass Filter | 84300-80037 |
| 3.5 GHz High Pass Filter | 84300-80038 |
| 8.25 GHz High Pass Filter | 84300-80039 |
| Through Cable | 84125-20019 |

4. Using the W2 semirigid cable, connect the filter or through cable to J1.
5. Be sure to torque all connectors to 8 inch-pounds using the 5/16 inch torque wrench provided (8710-1765).

18 to 26.5 GHz Configuration

Note

- If an antenna is already installed, you may need to remove the antenna and any associated cables or filters before installing another antenna.
- When performing the following antenna installation, only finger tighten connectors keeping all connections loose until the last step.

1. Remove the antenna clamp from the front of the antenna mounting plate using the Torx #10 screwdriver supplied. See Figure 4-3 below.

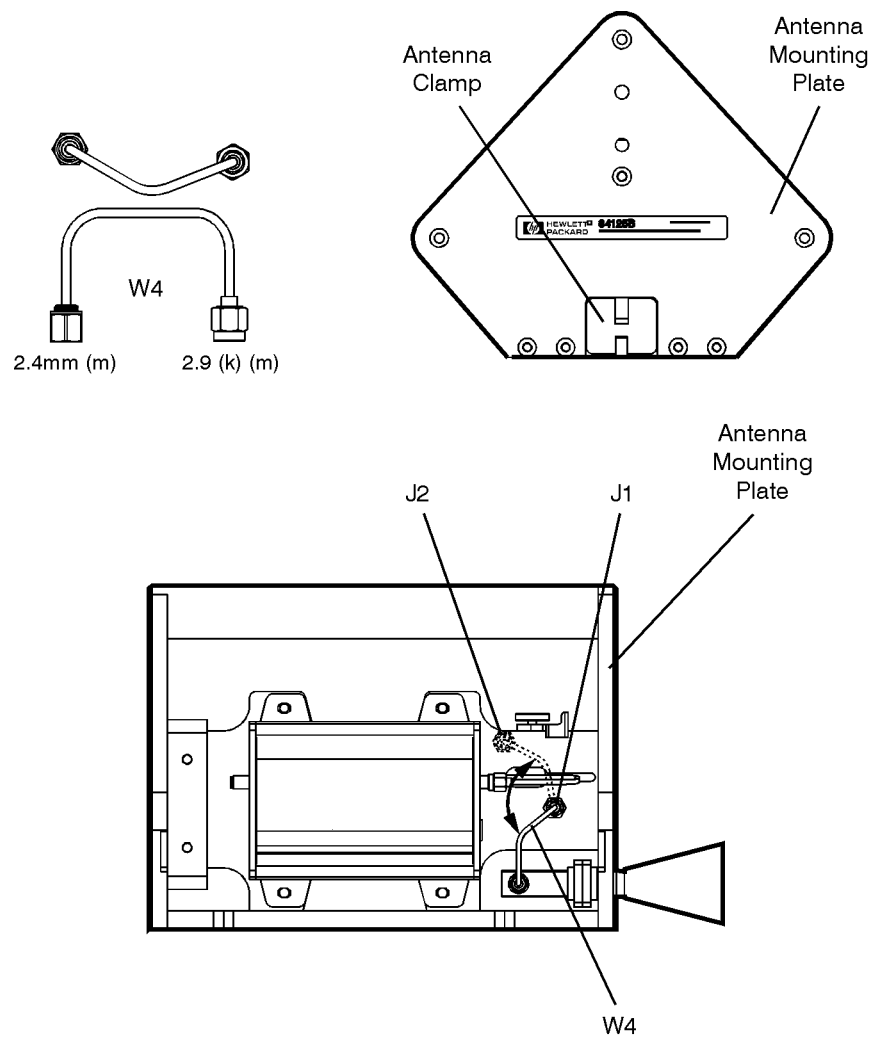

bview

Figure 4-3. 18 to 26.5 GHz Test-Set Configuration (side view)

2. Position the antenna in the larger of the two slots of the antenna clamp, placing the antenna clamp between the antenna horn and the waveguide flange.

3. Reinstall the clamp containing the antenna to the front plate and finger tighten the clamp screws. See Figure 4-3. Make sure that the antenna connector is pointed toward the left of the test set when viewed from the front of the test set.
4. Select the W4 semirigid cable and install it between the antenna output and the J1 connector. Verify that the 2.92 mm (K) connector is attached to the antenna and the 2.4 mm connector (the 2.4 mm end has a loose nut) is attached to J1.
5. Be sure to torque all connectors to 8 inch-pounds using the 5/16 inch torque wrench provided (8710-1765).
6. Tighten the antenna clamp screws using the Torx #10 screwdriver.

26.5 to 40 GHz Configuration

Note

- If an antenna is already installed, you may need to remove the antenna and any associated cables or filters before installing another antenna.
- When performing the following antenna installation, only finger tighten connectors keeping all connections loose until the last step.

1. Remove the antenna clamp from the front of the antenna mounting plate using the Torx #10 screwdriver supplied. See Figure 4-4 below.

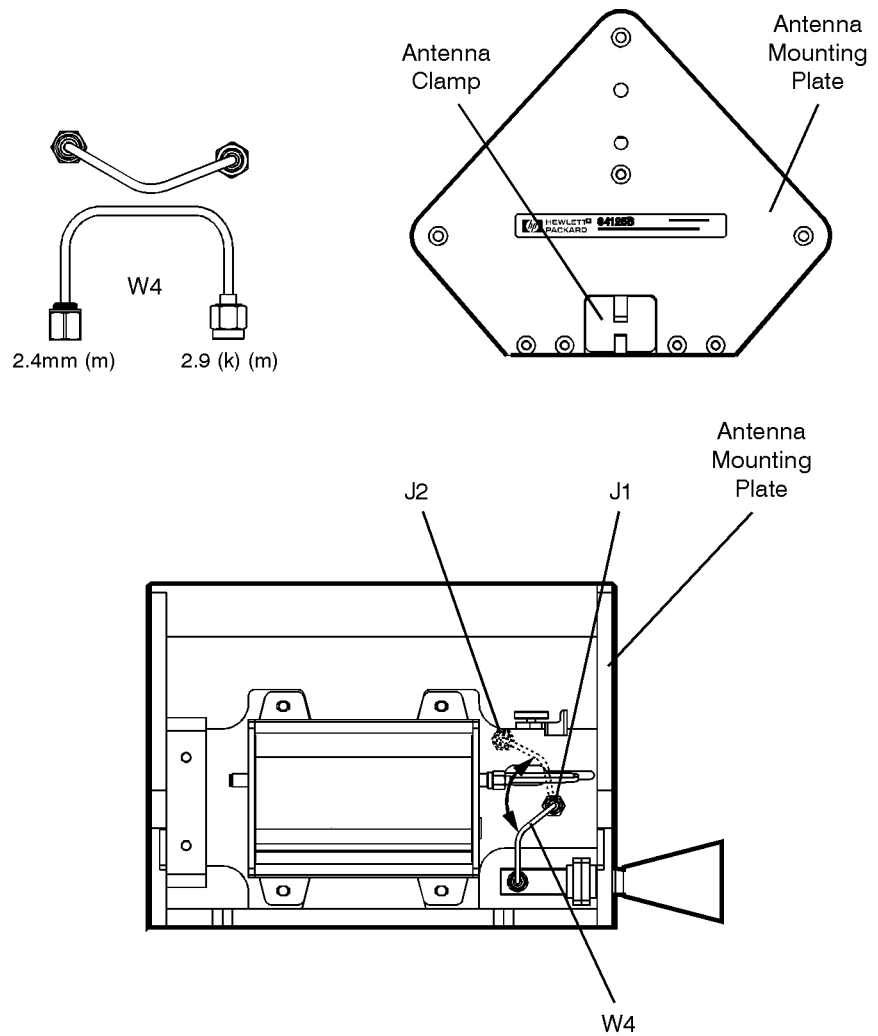

Figure 4-4. 26.5 to 40 GHz Test-Set Configuration (side view)

2. Position the antenna in the smaller of the two slots of the antenna clamp, placing the antenna clamp between the antenna horn and the waveguide flange.

3. Reinstall the clamp containing the antenna to the front plate and finger tighten the clamp screws. See Figure 4-4. Make sure that the antenna connector is pointed toward the left of the test set when viewed from the front of the test set.
4. Select the W4 semirigid cable and install it on the antenna. Verify that the 2.92 mm (K) connector is attached to the antenna and the 2.4 mm connector (the 2.4 mm end has a loose nut) is attached to J1.
5. Be sure to torque all connectors to 8 inch-pounds using the 5/16 inch torque wrench provided (8710-1765).
6. Tighten the antenna clamp screws using the Torx #10 screwdriver.

Cable and Connector Care

Instrument sensitivity and coaxial connector mechanical tolerances are such that slight errors in operator technique can have a significant effect on measurements and measurement uncertainties. *The most common cause of measurement error is poor connections.*

Note

The term “connector” will be used in the following procedures to describe the connection ends of the semirigid cables, filters, and adapters supplied with this system

Follow these recommendations for optimum connection technique:

- Clean and inspect (visually and mechanically) all connectors, cables, and filters.
- Align connectors carefully. Look for flat physical contact at all points on the mating plane surfaces.
- Make a gentle, preliminary connection.
- When you make a connection, turn *only* the connector nut. Do not rotate a device when you make a connection and do not apply lateral or horizontal (bending) force.

Connection Procedure

1. Visually inspect the connectors.
2. If necessary, clean the connectors. Use a 99.5% Isopropyl Alcohol solution (HP part number 8500-5344).
3. Carefully align the connectors.

The male connector center pin must slip concentrically into the contact fingers of the female connector.

4. Push the connectors straight together. Do *not* twist or screw them together. As the center conductors mate, there is usually a slight resistance.
5. The preliminary connection is tight enough when the mating plane surfaces make uniform, light contact. Do not overtighten this connection.

At this point all you want is a connection in which the outer conductors make gentle contact at all points on both mating surfaces. Very light finger pressure (no more than 2 inch-pounds of torque) is enough.

6. Torque final connections to 8-inch lbs.

Disconnection Procedure

1. Use a wrench to loosen the connector nut.
2. Complete the disconnection by hand, turning only the connector nut.
3. Pull the connectors straight apart without twisting or bending.

Handling and Storage

- Store the semirigid cables and filters in the foam-lined storage tray.
- Never store the cables or filters loose in a box, in a desk, or in a bench drawer. This is the most common cause of connector damage during storage.
- Keep connectors clean.
- Do not touch mating plane surfaces. Natural skin oils and microscopic particles of dirt are easily transferred to a connector interface and are very difficult to remove.
- Do not set connectors contact-end down on a hard surface. The plating and the mating plane surfaces can be damaged if the interface comes in contact with any hard surface.
- When you are not using a connector, use plastic end caps over the mating plane surfaces to keep them clean and protected.

System Interface

To combine the functionality of the HP 8564E spectrum analyzer and the test set, a downloadable program (DLP) has been provided. The DLP provides the system softkeys that set the parameters for making an EMI measurement. Frequency ranges associated with the test set hardware configurations, can be selected enabling you to test the harmonic frequencies of your equipment under test (EUT) while filtering out the fundamental frequencies. Correction data is used to sum out gains/losses due to the antenna, cables, amplifiers, and filters. In the Log mode, the values displayed by the HP 84125C system are the actual field strength of the emission (in $\text{dB}\mu\text{V}/\text{m}$), corrected for all system gains and losses including the antenna transducers factors. In the Linear mode, only the marker values are corrected and displayed by the HP 84125C system (in $\text{dB}\mu\text{V}/\text{m}$). The spectrum analyzer is automatically set up for optimum signal identification.

DLP Softkey Menu

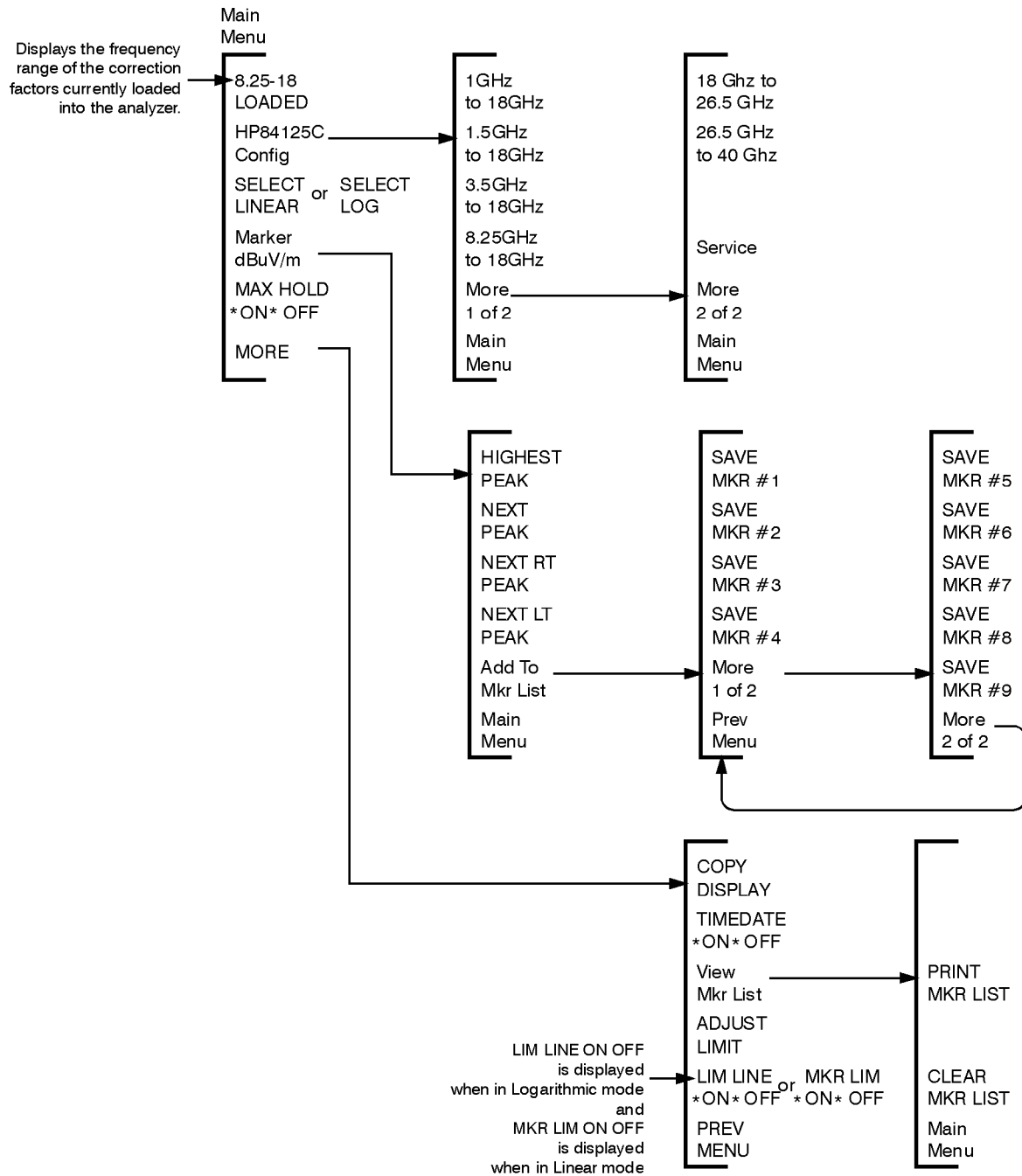

softkeys

Figure 5-1. DLP softkey menu

HP 84125C System Softkey Reference

The softkey reference describes the function of each of HP 84125C system softkeys. Refer to the *HP 8560 E-Series Spectrum Analyzer User's Guide* for a complete description of the spectrum analyzer front-panel keys and softkeys. To access the HP 84125C system softkeys press (MODULE), USER KEYS .

For your convenience, the top softkey placeholder (that is, top right-hand corner of the screen) shows the frequency range of the correction factors currently loaded into the spectrum analyzer. It is also used to preset the HP 84125C system interface conditions in case the spectrum analyzer (PRESET) key is pressed or the power is turned off. The system interface preset conditions are as follows:

| | |
|---------------------------------|---|
| Reference level: | 70 dB μ V or last defined LOG state |
| Start and stop frequencies: | selected configuration state |
| Limit line value: | 64 dB μ V/m or last defined state |
| Limit line on off: | On or last defined state |
| Amplitude scale mode: | Logarithmic |
| Amplitude scale: | 10 dB per division |
| Input Attenuation: | 20 dB |
| Resolution bandwidth (RBW): | 1 MHz |
| Video bandwidth (VBW): | 3 MHz |
| Amplitude Corrections (AmpCor): | On |
| Reference level offset: | specific for each configuration band |

1GHz
to 18GHz

Softkey that loads the correction data and parameters for the 1 to 18 test set configuration. This includes the corresponding test-set amplitude-correction data (that is, the amplifiers and cables are summed together), antenna correction data, and appropriate spectrum analyzer settings for making an EMI measurement.

Note

The 1GHz to 18GHz softkey depends on the test-set hardware being properly configured. That is, the test set must be configured in the 1 to 18 GHz configuration with the through cable and antenna that corresponds to the softkey selection.

Key Path

| | | | |
|----------|-----------|-----------------|---------------|
| (MODULE) | USER KEYS | HP84125C Config | 1GHz to 18GHz |
|----------|-----------|-----------------|---------------|

1.5GHz
to 18GHz

Softkey that loads the correction data and parameters for the 1.5 to 18 GHz test-set configuration. This includes the corresponding test-set amplitude-correction data (that is, the 1.5 GHz high-pass filter, amplifiers, and cables are summed together), antenna correction data, and appropriate spectrum analyzer settings for making an EMI measurement.

Note

The 1.5GHz to 18GHz softkey depends on the test-set hardware being properly configured. That is, the test set must be configured in the 1.5 to 18 GHz configuration with the through cable and antenna that corresponds to the softkey selection.

Key Path

| | | | |
|----------|------|----------|----------|
| | USER | HP84125C | 1.5GHz |
| (MODULE) | KEYS | Config | to 18GHz |

3.5GHz
to 18GHz

Softkey that loads the correction data and parameters for the 3.5 to 18 GHz test-set configuration. This includes the corresponding test-set amplitude-correction data (that is, the 3.5 GHz high-pass filter, amplifiers, and cables are summed together), antenna correction data, and appropriate spectrum analyzer settings for making an EMI measurement.

Note

The 3.5GHz to 18GHz softkey depends on the test-set hardware being properly configured. That is, the test set must be configured in the 3.5 to 18 GHz configuration with the through cable and antenna that corresponds to the softkey selection.

Key Path

| | | | |
|----------|------|----------|----------|
| | USER | HP84125C | 3.5GHz |
| (MODULE) | KEYS | Config | to 18GHz |

8.25GHz
to 18GHz

Softkey that loads the correction data and parameters for the 8.25 to 18 GHz test-set configuration. This includes the corresponding test-set amplitude-correction data (that is, the 8.25 GHz high-pass filter, amplifiers, and cables are summed together), antenna correction data, and appropriate spectrum analyzer settings for making an EMI measurement.

Note

The 8.25GHz to 18GHz softkey depends on the test-set hardware being properly configured. That is, the test set must be configured in the 8.25 to 18 GHz configuration with the through cable and antenna that corresponds to the softkey selection.

Key Path

| | | | |
|----------|------|----------|-----------|
| | USER | HP84125C | 8.25GHz |
| (MODULE) | KEYS | Config | to 18 GHz |

18GHz
to 26.5 GHz

Softkey that loads the correction data and parameters for the 18 to 26.5 GHz test-set configuration. This includes the corresponding test-set amplitude-correction data (that is, amplifiers and cables are summed together), antenna correction data, and appropriate spectrum analyzer settings for making an EMI measurement.

Note

The 18GHz to 26.5 GHz softkey depends on the test-set hardware being properly configured.

Key Path

| | | | | |
|----------|------|----------|--------|-------------|
| | USER | HP84125C | More | 18GHz |
| (MODULE) | KEYS | Config | 1 of 2 | to 26.5 GHz |

26.5 GHz
to 40GHz

Softkey that loads the correction data and parameters for the 26.5 to 40 GHz test-set configuration. This includes the corresponding test-set amplitude-correction data (that is, amplifiers and cables are summed together), antenna correction data, and appropriate spectrum analyzer settings for making an EMI measurement.

Note

The 26.5 GHz to 40GHz softkey depends on the test-set hardware being properly configured.

Key Path

| | | | | |
|----------|------|----------|--------|----------|
| | USER | HP84125C | More | 26.5 GHz |
| (MODULE) | KEYS | Config | 1 of 2 | to 40GHz |

Add to
Mkr List

Softkey that accesses the menu used to save marker values in one of nine storage locations. The marker values must first be generated by pressing **MARKER dB μ V/m**.

Key Path

| | | | |
|----------|------|------------|----------|
| | USER | MARKER | Add to |
| (MODULE) | KEYS | dB μ V | Mkr List |

**ADJUST
LIMIT**

Softkey that sets the upper limit line value in Logarithmic mode and the Marker Limit value in Linear mode. Use the data entry keys to enter a value from 10 to 110 dB μ V/m, then press **GHz +dBm dB** to enter the limit value.

Key Path

MODULE USER ADJUST
KEYS More LIMIT

**CLEAR
MKR LIST**

Softkey that clears the data stored in the nine registers of the marker list.

Key Path

MODULE USER View CLEAR
KEYS More Mkr List MKR LIST

**COPY
DISPLAY**

Softkey that copies the graticule, trace, limit line, labels, and displayed marker (that is, the marker value displayed when the **MARKER dB μ V/m** key is pressed) to an external printer.

Key Path

MODULE USER COPY
KEYS More DISPLAY

**HIGHEST
PEAK**

Softkey that moves the active marker to the highest signal in the trace.

Key Path

MODULE USER MARKER HIGHEST
KEYS dB μ V/m PEAK

**HP84125C
Config**

Softkey that accesses a menu to specify the frequency range of the test-set configuration. When a frequency range is selected, the corresponding test-set amplitude-correction data (which includes filter, amplifiers, and cables), antenna-correction data, and appropriate spectrum analyzer settings are automatically loaded.

Note

In Logarithmic mode, when correction data is loaded and turned on, the letter “W” appears in the lower left-hand side of the spectrum analyzer screen. The appropriate correction data must be loaded for the selected hardware when using the HP 84125C system for valid measurements.

Key Path

| | | |
|----------|------|----------|
| | USER | HP84125C |
| (MODULE) | KEYS | Config |

LIM LINE
ON OFF

Only available in Logarithmic mode.

Softkey that turns the limit line on and off. A fail message will be displayed if any signal onscreen exceeds the displayed limit line.

Note

- LIM LINE ON OFF is replaced by MKR LIM ON OFF when the Linear mode is selected.
 - The limit line value is set using the ADJUST LIMIT softkey. When switching from the Logarithmic to Linear mode, this same value will be used for the Marker Limit value.
-

Key Path

| | | |
|----------|------|-------------|
| | USER | LIM LINE |
| (MODULE) | KEYS | More ON OFF |

MARKER
dB μ V/m

Softkey that displays the amplitude of the active marker in dB μ V/m. When no markers are turned on, a marker at the center frequency will be displayed with the corresponding marker amplitude. In Linear mode, only the marker is corrected by the calibration value for this frequency.

MARKER dB μ V/m also accesses a menu of marker search functions allowing you to use marker functions within the DLP.

If the marker frequency is outside of the configured frequency range, no value will be displayed and an error message will appear in the title area. Only a valid marker will be saved when the Add to Mkr List function is selected.

Key Path

| | | |
|----------|------|--------------|
| | USER | MARKER |
| (MODULE) | KEYS | dB μ V/m |

MAX HOLD
ON OFF

Softkey that when on, maintains the maximum level for each trace and updates the trace if a new maximum level is detected in successive sweeps. When off, erases previously stored screen data and continuously updates the display during successive sweeps of the analyzer.

Note

The Max Hold function is only available for Trace A.

Key Path

(MODULE) USER MAX HOLD
KEYS ON OFF

MKR LIM
ON OFF

Only available in Linear mode.

Softkey that will activate a Marker Limit value. When **MARKER dB μ V/m** is pressed, the signal at the marker frequency is compared against this value. A fail message will be displayed if the amplitude of the marker exceeds the Marker Limit value.

Note

- MKR LIM ON OFF is replaced by LIM LINE ON OFF when the Logarithmic mode is selected.
- The limit value is set using the ADJUST LIMIT softkey. When switching from the Linear to Logarithmic mode, this same value will be used for the Limit Line value.

Key Path

(MODULE) USER MKR LIM
KEYS More ON OFF

NEXT
PEAK

Softkey that moves the active marker to the next higher signal in the trace.

Note

The Peak Excursion and Peak Threshold functions are used to define what constitutes a peak on a trace. Refer to “Key Function Descriptions” in the *HP 8560 E-Series Spectrum Analyzer User’s Guide* for a complete description of these functions.

Key Path

(MODULE) USER MARKER NEXT
KEYS dB μ V/m PEAK

NEXT LT
PEAK

Softkey that moves the active marker to the next signal left of the current position.

Note

The Peak Excursion and Peak Threshold functions are used to define what constitutes a peak on a trace. Refer to “Key Function Descriptions” in the *HP 8560 E-Series Spectrum Analyzer User’s Guide* for a complete description of these functions.

Key Path

(MODULE) USER MARKER NEXT LT
KEYS dB μ V/m PEAK

NEXT RT
PEAK

Softkey that moves the active marker to the next signal right of the current position.

Note

The Peak Excursion and Peak Threshold functions are used to define what constitutes a peak on a trace. Refer to “Key Function Descriptions” in the *HP 8560 E-Series Spectrum Analyzer User’s Guide* for a complete description of these functions.

Key Path

(MODULE) USER MARKER NEXT RT
KEYS dB μ V/m PEAK

PRINT
DISPLAY

Softkey that prints a copy of the test set gain measurement values for performance verification to an external printer. These values will be used to complete the System Functional tests.

Key Path

(MODULE) USER HP84125C More PRINT
KEYS Config 1 of 2 Service DISPLAY

PRINT
MKR LIST

Softkey that prints a copy of the marker list to an external printer.

Key Path

(MODULE) USER View PRINT
KEYS More Mkr List MKR LIST

SAVE
MKR #1 - #9

Softkey that saves the amplitude, frequency, and the amplitude scale (that is, logarithmic or linear) using the values determined by the MARKER dB μ V/m function. These values will be saved in the marker register until the markers are cleared using the CLEAR MKR LIST function or a new value is stored overwriting the existing value.

Key Path

| | | | | |
|----------|------|------------|----------|-------------|
| | USER | MARKER | Add To | SAVE |
| (MODULE) | KEYS | dB μ V | Mkr List | MKR #1 - #9 |

SELECT
LINEAR

Softkey that changes the display to a linear amplitude scale. When SELECT LINEAR is pressed, a marker will be turned on and positioned on the highest signal in the trace. This marker frequency will be used to determine the correction value for the new (that is, Linear mode) reference level. The Linear mode reference level is a function of this correction value and the Logarithmic mode reference level. If the marker is outside the frequency range of the selected configuration, an error message will appear in the title area, but conversion to the Linear mode will continue using the correction value of the last valid marker.

Note

The label on this softkey toggles between SELECT LINEAR and SELECT LOG .

Key Path

| | | |
|----------|------|--------|
| | USER | SELECT |
| (MODULE) | KEYS | LINEAR |

SELECT
LOG

Softkey that changes the display to a logarithmic amplitude scale. When SELECT LOG is pressed, the Reference Level returns to the value prior to selecting the Linear mode. In case the measurement of a smaller signal level is desired, simply adjust the reference level as needed.

Note

The label on this softkey toggles between SELECT LOG and SELECT LINEAR .

Key Path

| | | |
|----------|------|--------|
| | USER | SELECT |
| (MODULE) | KEYS | LOG |

SERVICE

Softkey that displays the test set gain measurement values for performance verification. These values will be used to complete the System Function tests.

Key Path

(MODULE) USER HP84125C More
KEYS Config 1 of 2 SERVICE

TIMEDATE ON OFF

Softkey that turns on and off the time and date stamp in the upper left-hand corner of the display. When on, the time and date will also appear on copies outputted to the printer using the COPY DISPLAY softkey.

Key Path

(MODULE) USER TIMEDATE
KEYS More ON OFF

VIEW MKR LIST

Softkey that displays the amplitude scale mode, frequency, and amplitude for the nine Save Marker functions.

Key Path

(MODULE) USER VIEW
KEYS More MKR
LIST

Making Measurements

The HP 84125C microwave EMI measurement test system may be used for a variety of measurements. To assure the best, most accurate measurements of your product, you should read and review the required product regulations. The following example describes one method for measuring the intentional radiation of a cellular telephone in accordance with the current FCC, Part 15 regulation. However, there are other methods that you can use that may work better for your testing environment.

Current FCC regulations specify that harmonic emissions measured above 1 GHz on wireless transmitters should be below $54 \text{ dB}\mu\text{V/m}$ using average detection at a distance of 3 meters. At higher frequencies, cable loss and antenna factors bring the inherent system noise level close to the regulatory limit. To improve the signal-to-noise ratio, the FCC allows positioning the measuring antenna at a distance closer than 3 meters. The correction to be applied is described in FCC, Part 15.31 (f)(1) which states:

“At frequencies equal to or above 30 MHz, measurements may be performed at a distance other than what is specified provided: measurements are not made in the near field; and, it can be demonstrated that the signal levels needed to be measured at the distance employed can be detected by the measuring equipment. Measurements shall not be performed at a distance greater than 30 meters unless it can be further demonstrated that measurements at a distance of 30 meters or less are impractical. When performing measurements at a distance other than what is specified, the results shall be extrapolated to the specified distance using an inverse linear distance extrapolation factor (20 dB/decade).”

This would translate to measuring to a limit of approximately $64 \text{ dB}\mu\text{V/m}$ at a distance of 1 meter. Therefore, we recommend that you first make a measurement at a distance of 1 meter to the $64 \text{ dB}\mu\text{V/m}$ limit line with peak detection. Using a 1 meter measurement will improve the signal-to-noise ratio making it easier to detect emissions. Signals with a peak value above the $64 \text{ dB}\mu\text{V/m}$ limit line will need to be remeasured using average detection.

Note

-
- This procedure describes the FCC requirement. Measurements to other regulatory standards would be similar but should use the limits, measuring distances, and procedures described in those regulations.
 - Even though the measurement is done specifically for harmonic emissions, any spurious emission from the test device that exceeds the limit also fails the specification.
 - If measured results using peak detection are significantly below the limit line (approximately 6 dB), further measurements are not required.
-

Configuring the Test Set

1. Determine the fundamental frequency of the equipment under test (EUT). For this example, a fundamental frequency of 830 MHz will be used for the cellular telephone, an intentional radiator.
2. Make a list of the harmonic frequencies that you will need to test. For 830 MHz, the ten harmonic frequencies to be tested are:
 - 1.66 GHz
 - 2.49 GHz
 - 3.32 GHz
 - 4.15 GHz
 - 4.98 GHz
 - 5.81 GHz
 - 6.64 GHz
 - 7.47 GHz
 - 8.30 GHz
3. The fundamental signal is usually 40 dB above the harmonics. In order to avoid overloading the spectrum analyzer first converter, a high-pass filter must be added. To filter out the fundamental frequency of 830 MHz, install the 1.5 GHz filter in the test set and ensure that the 1 to 18 GHz antenna is installed. Refer to Figure 4-2 to assist you with this procedure.
4. On the spectrum analyzer, press the following key sequences:
 - a. `(PRESET)`, `(MODULE)`, `USER KEYS`
 - b. `HP84125C Config`, `1.5GHz to 18GHz`

This selects the amplitude correction factors for the 1.5 to 18 GHz filter signal path and the 1 to 18 GHz horn (from 1.5 to 18 GHz). The resolution bandwidth is set to 1 MHz and the video bandwidth is set to 3 MHz.

Setting Up the HP 8564E Spectrum Analyzer

Set up the spectrum analyzer to measure harmonic emissions as follows:

1. Press **(FREQUENCY)**, **CENTER FREQ** 1.66 **(GHz)** to set the center frequency to the first harmonic.
2. Press **CF STEP AUTO MAN**, 830 **(MHz)** to set the center frequency step size of 830 MHz.
3. Press **(SPAN)**, 100 **(MHz)**, or to a value that allows you to clearly discern the signals.
4. Set up the limit line for a 1-meter FCC test by pressing, **(MODULE)**, **USER KEYS**, **MORE**, **LIM LIN *ON* OFF** **ADJUST LIMIT** 64 **(dBm)**, or the appropriate limit for the regulation being tested.

Making the Measurement Using Peak Detection

1. Place the EUT (in this case, the cellular telephone) on a nonconductive surface and position the antenna 1 meter away from the cellular telephone at the height specified by the regulation. Make sure that the cellular telephone is on.
2. Move the antenna 360° around the EUT to find the direction of maximum radiation for the first harmonic (that is, 1.66 GHz). The test set has been designed with three handles to make it easy to use in both vertical and horizontal polarizations.
3. If the noise level at the frequency of the emission is greater than 10 dB below the limit, move the antenna to 3 meters away from the EUT and repeat the above procedure. For emissions that fall close to the 64 dB μ V/m limit line, the limit line can be changed to 54 dB μ V/m (the 3-meter limit)
 - a. Press **ADJUST LIMIT** 54 **(dBm)**.

If the amplitude of the signals fall significantly below either the 54 dB μ V/m display line (approximately 6 dB) at a distance of 3 meters or 64 dB μ V/m limit line at 1 meter or less, then the harmonic amplitude passes the requirement.

Tip

Make a list of the signals that fail this guideline, then repeat the procedure using average detection after all of the harmonics have been tested using peak detection.

4. Press **(AMPLITUDE)**, **REF LVL** and adjust the reference level to bring the signal near the top of the display.
5. To record the amplitude of the harmonic:
 - a. Press **(MODULE)**, **USER KEYS**, **MARKER dB μ V/m** to activate the marker on screen and several marker functions.

Note

If the signal of interest is greater than 2.9 GHz, perform a preselector peak by pressing, **(AMPLITUDE)**, **MORE 1 OF 3**, **MORE 2 OF 3**, **PRESEL AUTO PK**.

- b. Press **HIGHEST PEAK** (or any of the marker function keys) to place the marker on the emission.

Notice that the amplitude of the marker is displayed in the upper left-hand corner of the screen.

- c. Press **ADD TO MKR LIST**, **SAVE MKR #1** to add the signal to the marker list.
-

Tip

To view the signals in the marker list, press **Main Menu**, **MORE**, **VIEW MKR LIST**.

- d. Press **(FREQUENCY)**, **CENTER FREQ**, **(D)** to set the center frequency to the next harmonic frequency.

- e. Repeat the above procedure for each harmonic frequency.
-

Note

For your convenience, we have provided a maximum hold feature that may be useful when the signal appears to be unstable or when printing out a copy of the graphics for a report. To access this functionality, press **(MODULE)**, **USER KEYS** then **MAX HOLD *ON* OFF**. If a copy of the display is required, press **MORE** then **COPY DISPLAY** softkeys to produce your output. Ensure that the appropriate printer or plotter is connected and configured. For more information, refer to the *HP 8560 E-Series Spectrum Analyzer User's Guide*.

Making a Measurement Using Average Detection

When the spectrum analyzer is used in linear mode, video filtering provides the average value of a signal. After the signal has been maximized and the peak value has been measured, an average measurement may be made.

Video (post-detection) filtering provides averaging of higher frequency components (such as noise) at the output of the envelope detector. When the video filter bandwidth is narrower than the resolution bandwidth filter, averaging occurs. Narrowband (for example, continuous-wave) signal amplitudes are not affected by video filtering.

For the true average, the video bandwidth must be less than the lowest pulse repetition frequency, the sweep must be slow enough to let the filters charge completely, and the spectrum analyzer must be in the linear amplitude display mode.

To make an average measurement:

1. Press **(PEAK SEARCH)**, **MARKER → CF** to place the emission at the center of the screen.
2. Press **(MKR)**, **SIG TRK ON OFF** with ON underlined.

3. Press **(SPAN)** **10 (MHz)**, or a frequency span that will make a calibrated measurement.
4. Press **(MKR)**, **SIG TRK ON OFF** with OFF underlined.
5. Press **(AMPLITUDE)**, **Ref Lvl** and adjust the reference level to bring the signal near the top of the display.
6. Press **(MODULE)**, **USER KEYS**, **SELECT LINEAR** to select a linear amplitude scale.

Note

- Amplitude correction is turned off in Linear mode. The **MARKER dB μ V/m** softkey must be used to make a dB μ V/m reading at a single point.
- Notice that the limit line is removed when in Linear mode. In Linear mode, the **MKR LIM ON OFF** softkey replaces the **LIM LINE ON OFF** softkey. When **MKR LIM ON OFF** is ON, a limit fail message will be displayed if the signal (using **MARKER dB μ V/m** or any of the corresponding peak search keys) exceeds the limit set.

-
7. Press **(AMPLITUDE)**, **Ref Lvl** and adjust the reference level to bring the signal near the top of the display.
 8. Press **(BW)**, **VIDEO BW AUTO MAN** with MAN underlined. Use the down arrow key to reduce the video bandwidth. Continue to reduce the video bandwidth until the trace becomes smoothed and ceases to change. Averaging occurs when the video bandwidth is smaller than the lowest pulse repetition frequency (PRF) of the signal being measured.

Note

If the signal of interest is greater than 2.9 GHz, perform a preselector peak by pressing, **(AMPLITUDE)**, **MORE 1 OF 3**, **MORE 2 OF 3**, **PRESEL AUTO PK**.

-
9. Press **(MODULE)**, **USER KEYS**, **MARKER dB μ V/m** to activate the marker.
 10. Press **HIGHEST PEAK**, or any of the other marker softkeys, to place the marker on the emission.
If the marker value exceeds the limit then the message, "LIMIT FAILED" will appear above the Corrected Linear Marker Value.
 11. Press **ADD TO MKR LIST**, **SAVE MKR #2** to add the signal to the marker list.

Tip

To view the signals in the marker list, press **Main Menu**, **MORE**, **VIEW MKR LIST**.

-
12. Press **Main Menu**, **SELECT LOG** to return to a logarithmic amplitude scale.

Using the HP 84125C Utility

The HP 84125C download utility disk is generated during factory calibration of the HP 84125C system. It is shipped with each system and is specific to that system. The download utility disk contains the DLP (that is, the system interface) and a Windows based program (HP 84125C download utility) that allows you to restore system calibration, modify antenna data, or print existing system correction factors. You can also view the test set gain factors and the antenna factors separately using text files contained on the same disk.

To use the HP 84125C download utility to restore correction factors in the HP 8564E spectrum analyzer, you will need a personal computer equipped with a GPIB interface to communicate with the spectrum analyzer. The GPIB interface is not for printing the correction factors to your local printer. The following sections describe the computer requirements and the use of the HP 84125C utility.

- Personal Computer Requirements
- Setting Up the HP-IB or GPIB Interface
- Installing the HP 84125C Download Utility on Your Personal Computer
 - Downloading the DLP into the Spectrum Analyzer
- File Menu
 - Printing Correction Factors
- Edit Menu
 - Editing Antenna Correction Factors
 - Configuring GPIB

Personal Computer Requirements

The following describes the minimum requirements of personal computer configuration.

Minimum PC Requirements

| | |
|---------------------|---|
| CPU | Intel 486/DX2 running at 66 MHz |
| RAM | 8 MBytes |
| Graphics | VGA 15-inch monitor with any Windows-supported video board |
| Hard Disk | Software installation requires 3 MByte free disk space |
| Floppy Disk | 3.5 inch high-density, 1.44 MByte |
| GPIB | Hewlett-Packard's HP-IB Interface or National Instruments Corporation's AT-GPIB/TNT |
| Working Environment | Windows 3.1, 3.11, or Windows 95 |
| Pointing Device | Any Windows 3.1 compatible mouse or trackball |

Setting Up the HP-IB or GPIB Interface

To use the HP 84125C utility, your personal computer will need a GPIB interface to communicate with the spectrum analyzer. You can use either the National Instruments Corporation's AT-GPIB interface board and NI-488.2 MS-DOS/Windows drivers, or the Hewlett-Packard HP-IB interface card to download the system correction factors to the spectrum analyzer. Most computers with Windows 3.1, 3.11, or Windows 95 installed have a diagnostic program called MSD (Microsoft Diagnostics) that can help in identifying base address and IRQ assignments. This program can most easily be accessed from the DOS prompt. In DOS, go to the windows directory and enter MSD. Other diagnostic programs may be used to determine valid IRQ and base address settings.

Setting Up HP-IB Interface for Windows 3.1

The HP-IB interface card (HP 82341C) can be configured and installed using the following three steps.

Hardware Installation

1. Shut down Windows 3.1 and turn off the computer.
2. Remove the computer cover and install the HP-IB interface card in one of the available slots. If possible, avoid using the first or last slot as it is difficult to connect the HP-IB interface cable with the card in either of these locations.

3. Use the default switch settings on the HP 82341C card.
4. Replace the computer cover, turn on the computer, and load Windows 3.1.

Software Installation

1. Place the HP/IO Libraries for Instrument Control compact disc (CD) into the CD drive of your computer to load the HP 84231C software.
2. Open Windows File Manager and select the CD ROM drive (for example, drive D).
3. From the File Manager, click on **Windows 3.1** then **disk 1**.
4. Select **Setup31.exe** to load the driver.
5. Verify the SICL and VTL files locations then press **Install**.
6. When the installation is complete, the message "Setup Succeeded" will be displayed. Click **OK**.
7. From the HP SICL group, select the I/O Config utility to configure your interfaces.
8. From the Available Interface Types area, select **HP 82340/82341** then click **OK**.
9. From the Configured Interfaces area, verify that the HPIB is set to 7. This value will need to be set in the GPIB Configuration of the HP 84125C Utility. Refer to "GPIB Configuration Window" for more information.
10. When the driver is successfully installed, recycle the power and restart Windows 3.1.

Setting Up HP-IB Interface for Windows 95

The HP-IB interface card (HP 82341C) can be configured and installed using the following three steps.

Hardware Installation

1. Shut down Windows 95 and turn off the computer.
2. Remove the computer cover and install the HP-IB interface card in one of the available slots. If possible, avoid using the first or last slot as it is difficult to connect the HP-IB interface cable with the card in either of these locations.
3. Use the default switch settings on the HP 82341C card.
4. Replace the computer cover, turn on the computer, and load Windows 95.

Software Installation

1. Place the HP/IO Libraries for Instrument Control compact disc (CD) into the CD drive of your computer to load the HP 84231C software.
2. From the Windows 95 Start menu, select **Start**, then **Run**.

3. From the Run dialog box, select the CD ROM drive. Use the Browse button if you do not know the location of the CD ROM drive.
4. Select **Setup.exe** to load the driver.
5. From the HP/IO Libraries Installation window, select **Windows 95**.
6. Verify the SICL and VTL files locations then press **Install**.
7. When the installation is complete, the message "Installation Succeeded" will be displayed. Click **OK**.
8. To complete the configuration, select **Start, Programs, HPI_O LIBRARIES, I_O Config**.
9. From the Configured Interfaces area, verify that the GPIB is set to 7. This value will need to be set in the GPIB Configuration of the HP 84125C Utility. Refer to "GPIB Configuration Window" for more information.
10. From the Available Interface Types area, select **HP 82340/ 82341 HP-IB** then click **Configure**.
11. Make any necessary changes then click **OK**.
12. When the driver is successfully installed, recycle the power and restart Windows 95.

Hardware Verification

1. Select **Start, Settings, Control Panel**.
2. From the Control Panel window, select the **System** icon.
3. From the System Properties window, select **Device Manager**.
4. Verify that **HP-IB** is listed.

There is no diagnostic test for the HP-IB card.

Setting Up HP-IB Interface for Windows NT 4.0

The HP-IB interface card (HP 82341C) can be configured and installed using the following three steps.

Hardware Installation (HP 82341C)

1. Shut down Windows NT and turn off the computer.
2. Remove the computer cover and install the HP-IB interface card. If possible, avoid using the first or last slots as it is difficult to connect the GPIB interface cable with the card in either of these locations.
Use the default switch settings on the HP 82341C card.
3. Turn on the computer to start Windows NT.

Software Installation

1. Place the HP/IO Libraries for Instrument control compact disc (CD) into the CD drive of your computer to load the HP 82341C software.

2. From the Windows NT **Start** menu, select **Run**.
3. In the Run dialog box, select the CD ROM drive. Use the Browse button if you do not know the location of the CD ROM drive.
4. Select **Setup.exe** to load the driver.
5. In the HP I/O Libraries Installation window, select **Windows NT**.
6. Verify the SICL and VTL file locations then press **Install**.
7. When the installation is complete, the message "Installation Succeeded" will be displayed. Click **OK**.
8. To complete the configuration, click on the Windows NT **Start** button, then select **Programs, HP SICL, and Windows NT I_O Config**.
9. In the Interface Configuration Application-I/O Config window, select **HP 82340/82341** in the Available Interface Types area then click **Add**.
10. Make any necessary changes then click **OK**.
11. Click **OK** again to exit the Interface Configuration Application window.
12. When the driver is successfully installed, recycle the power and restart Windows NT.

Hardware Verification (HP 82341C)

1. From the Windows NT **Start** menu, select **Settings** then **Control Panel**.
2. In the Control Panel window, double-click on the **Devices** icon.
3. In the Devices window, scroll down and verify **hp341i32** is listed.
There is no diagnostic test for the HP-IB card.

Setting Up AT-GPIB for Windows 3.1

The following four sections describe the Windows 3.1 setup and installation of both hardware and software for the AT-GPIB interface card. For complete installation and configuration instructions, refer to the National Instruments documentation, *Getting Started with Your AT-GPIB/TNT, NI-488.2 Software for Windows*, and *Using Your NI-488.2 software for DOS or Windows 3 with Windows 95*.

Hardware Setup and Installation

1. Remove the DMA jumper on the AT-GPIB/TNT board; this sets the DMA to **none**.
2. Set the Base I/O Address to an unused address in your personal computer. The default Base I/O Address is (hex) 2C0.
3. Set the Interrupt Level (IRQ) to an unused interrupt in your personal computer. The default Interrupt Level is 11.
4. Insert the GPIB board into an unused 16-bit ISA slot of your personal computer. In order to ensure proper GPIB connection,

avoid inserting the GPIB board into either the first or last slot as it is difficult to connect the HP-IB interface cable with the card in either of these locations.

Software Installation

1. Insert the NI-488.2 Software for Windows and the AT-GPIB/TNT disk into the disk drive.
2. Run **Setup.exe**.
3. Follow the setup instructions displayed on the computer screen to complete the installation.

Software Setup

After installation of the NI-488.2 software, the windows group NI-488.2 GPIB Software will be created. Prior to verifying proper operation of the hardware and software installation, you will need to perform the following procedure:

1. In Program Manager, double-click on the **Main** group icon.
2. In the Main group, double-click on the **Control Panel** icon then double-click on **GPIB**.
3. In the GPIB Configuration window, with the GPIB0 board highlighted, click on the **Configure** button.

Note

This value (that is, GPIB0) will need to be set later in the GPIB Configuration of the HP 84125C Utility. Refer to “GPIB Configuration Window” for more information.

4. In the GPIB0 (AT-GPIB/TNT) window, click on the DMA Channel drop-down list box and select **None**.
5. Set the Base I/O Address and IRQ to the same values set on the card in steps 2 and 3 above in “Hardware Setup and Installation”.
6. Record the Base I/O Address _____ and the Interrupt Level _____.
7. Click on the **OK** button.
8. Click on the **OK** button in the GPIB Configuration window to exit the GPIB application.

Hardware Verification

1. In the NI-488.2 GPIB Software group, double-click on the **Hardware Diagnostic Test** icon to access the IBDIAG window that verifies proper hardware operation.

Read the information and follow all instructions. Press <**Enter**> on the keyboard to all prompts except for the DMA Channel prompt which requires you to enter an **N**.

2. After verifying that the “AT-GPIB passed IBDIAG,” enter **q** and press <**Enter**> to exit the Hardware Diagnostic Test.

3. In the NI-488.2 GPIB Software group, double-click on the **Software Diagnostic Test** icon to access the IBTEST window that verifies proper software operation.

Read the information and follow the instructions.

4. Click on **File** then **Exit** to exit the Software Diagnostic Test.

Setting Up AT-GPIB/TNT for Windows 95

The following four sections describe the Windows 95 setup and installation of both hardware and software for the AT-GPIB interface card.

Note

The drivers shipped with the TNT card will not work under Windows 95. Download the driver for Windows 95 Version 1.1, or later, from the National Instrument's Web site at <http://www.natinst.com>. For this installation, the software *must* be installed before the hardware.

Software Installation

1. From the Windows 95 Start menu, select **Settings, Control Panel**, then the **Add/Remove Programs** icon.
2. Insert the NI-488.2 Software for Windows and the AT-GPIB/TNT disk 1 into the disk drive.
3. From the Add/Remove Programs menu, select **Install**.
4. Follow the setup instructions displayed on the computer screen to complete the installation. From the GPIB setup options, select the **GPIB setup option from the NI 488.2 (M) software**.

Hardware Configuration

Follow the procedure below to configure the hardware BEFORE it is installed.

1. From the Windows 95 Start menu, select **Settings, Control Panel**, then **Add New Hardware**.
2. Start the Add New Hardware wizard by clicking on **Next**. When it prompts you to search for hardware click on **No**. (This is because the hardware has not been installed yet.)
3. Click **Next** to display the driver software, then double-click on the **National Instruments** software. Select **AT-GPIB/TNT** then **Next**.
4. The Add New Hardware wizard will display the I/O range, DMA, and Interrupt Request for the AT-GPIB/TNT card.
5. Use the settings from the step above to configure the AT-GPIB/TNT card. Refer to the *AT-GPIB/TNT Getting Started* manual to assist you with this procedure.
6. When Windows 95 has finished installing the software necessary for supporting your hardware, click on **Next** to end the installation. When the software prompts you to power down the computer, click on **Yes**.

Hardware Installation

1. Shut down Windows 95 and turn off the computer.
2. Remove the computer cover and install the GPIB interface card. If possible, avoid using the first or last slot as it is difficult to connect the GPIB interface cable with the card in either of these locations.
3. Turn on the computer and load Windows 95.

Hardware Verification

1. Select **Start, Settings, Control Panel**.
2. From the Control Panel window select the **System** icon.
3. From the System window, select **Device Manager** then **National Instruments**.
4. Select **AT-GPIB/TNT, Properties**, then **Resources**. Verify that the I/O range, DMA, and Interrupt Request are the same values as what were set on the card, and there are no conflicts.
5. Close out the Control Panel category.
6. To test the AT-GPIB/TNT card, select **Start, Program, NI 488.2M Software for Windows 95, Diagnostics**.
7. From the Diagnostics window, select **Test All**.
8. When the message "Please close all GPIB applications" appears, select **OK**.
9. When the test is complete "Passed" will be displayed. Select **OK**. If the test does not pass, refer to the *AT-GPIB/TNT Getting Started* manuals for more information.

Setting Up AT-GPIB/TNT for Windows NT 4.0

The following four sections describe the Windows NT 4.0 setup and installation of both hardware and software for the AT-GPIB interface card.

Software Installation

1. Insert the NI-488.2 Software for Windows and the AT-GPIB/TNT disk into the disk drive.
2. Run **setup.exe**.
3. Follow the setup instructions displayed on the computer screen to complete the installation.

Hardware Setup and Installation

1. Select an unused DMA. If there is a conflict, remove the DMA jumper on the AT-GPIB/TNT board; this sets the DMA to **none**.
2. Set the Base I/O Address to an unused address in your personal computer. The default Base I/O Address is (hex) 2C0.
3. Set the Interrupt Level (IRQ) to an unused interrupt in your computer. The default Interrupt Level is 11.

4. Shut down Windows NT and turn off the computer.
5. Remove the computer cover and install the GPIB interface card. If possible, avoid using the first or last slot as it is difficult to connect the GPIB interface cable with the card in either of these locations.
6. Turn on the computer and start Windows NT.

Software Setup

After installation of the NI-488.2 software, the windows group **NI-488.2 GPIB Software** will be created. Prior to verifying proper operation of the hardware and software installation, you will need to perform the following steps.

1. From the Windows NT **Start** menu, select **Settings, Control Panel**, then double-click on the GPIB icon.
2. In the GPIB Configuration window, with the GPIB0 board highlighted, click on the **Configure** button.
3. In the GPIB0 (AT-GPIB/TNT) window, click on the DMA Channel drop-down list box and set the DMA to the value set on the card in step 1 of "Hardware Setup and Installation".
4. Set the Base I/O Address and IRQ to the same values set on the card in steps 2 and 3 of "Hardware Setup and Installation".
5. Click on the **OK** button.
6. Click on the **OK** button in the GPIB Configuration window to exit the GPIB application.

Hardware Verification AT-GPIB/TNT

It is important to test your hardware configuration before attempting to use the AT-GPIB interface. Use the following procedure to verify correct operation.

1. From the Windows NT **Start** menu, select **Programs, NI-488.2M for Windows NT, Diagnostic**.
2. In the Diagnostic window, click on the **Test All** button.
3. When the test is complete, click on the **Exit** button to exit the software diagnostic test.

Installing the HP 84125C Download Utility on Your Personal Computer

In the event that the spectrum analyzer memory is inadvertently cleared and the DLP lost, it can be reloaded from the HP 84125C download utility disk via your personal computer. You can also use the download utility to edit or print antenna correction factors. Refer to “Antenna Factors” for more information.

Use the following procedure to install the HP 84125C download utility on your personal computer.

Note

Hewlett-Packard recommends that you make a backup copy of the HP 84125 download utility disk before attempting to install the utility on the computer.

1. Insert the HP 84125C system download utility disk into the disk drive of the personal computer.
2. Open MS-Windows File Manager and select the floppy disk drive (for example, drive A) then double-click on **install.exe**. To complete your setup, follow the instructions on the computer screen.

Downloading the DLP into the Analyzer

To use the HP 84125C Download Utility to reload the DLP, follow the procedure below.

- Connect a GPIB interface cable from the GPIB connector on the rear panel of the personal computer to the HP-IB connector on the rear panel on the spectrum analyzer.
- Double-click on the HP 84125C Download utility icon to run the download utility, then click on **Download**. The DLP, including the system correction factors, will be restored in the spectrum analyzer.

File Menu

The File menu provides the functions to print amplitude correction data for the hardware configurations and to exit the HP 84125C Utility.

Print Factors

The Print Factors File menu item allows you to print the amplitude correction data for all of the hardware configurations (that is, 1 to 18 GHz, 1.5 to 18 GHz, 3.5 to 18 GHz, 8.25 to 18 GHz, 18 to 26.5 GHz, and 26.5 to 40 GHz).

Exit

Exit closes the HP 84125C Utility.

Edit Menu

The Edit menu provides the functions to edit the antenna correction factors and to configure the GPIB interface card.

Antenna Factors

Opens the Edit Antenna Factors window which is used to select the antenna for correction factor editing. Click on the drop-down list box, then select one of the three system antennas.

Antenna correction factors are provided by the antenna manufacturer. Antenna factors are conversion factors relating field strength to measured voltage.

- HP 11964E (EMCO 3115), 1 to 18 GHz
- HP part number 84125-80008 (EMCO 3160-09), 18 to 26.5 GHz
- HP part number 84125-80001 (EMCO 3160-10), 26.5 to 40 GHz

Antenna Correction Factors Window

The Antenna Correction Factors window is used to edit the existing correction factors for the selected antenna.

Antenna Data Area

The Antenna Data area displays the selected antenna correction factors. Each data point contains a corresponding frequency and correction factor. Use the mouse or up and down arrow keys on the keyboard to select a data point for editing. Once a data point is highlighted, the corresponding frequency and correction factor is placed in the Edit area for editing.

Edit Area

The Edit area displays the selected antenna correction data for editing. You may edit the frequency (in GHz) and the antenna correction factor (in dB/m) for any of the data points. Use either the Tab key or the mouse to move from the Freq (GHz) area to the Correction (dB/m) area.

Enter Point Button

The Enter Point button enters the newly edited data for the correction point. You can also use the Tab key to enter the correction data. Using the Tab key will also select the next data point for editing.

Note

If you change the frequency of the point such that it is no longer in sequence with the other frequencies, a warning screen will appear telling you that the list will be resorted if you continue. If you choose OK, the point will be entered and the list resorted.

Del Point Button

The Delete Point button removes the highlighted data point with its corresponding frequency-correction factor from the Antenna Data area.

Note

If you want to recover a data point that has been deleted, you can Exit the Antenna Correction Factors window without saving the antenna factors. Then, re-enter the Antenna Correction Factors window and start editing again. Once you Save the factors, the old data cannot be recovered unless you have backed up the files.

Add Point Button

The Add Point button adds a new frequency-correction point to the end of the list in the Antenna Data area. You may then edit that point. Changing the frequency of the point will move it to the appropriate location in the list.

Save Button

The Save button saves the antenna correction factor points in the appropriate file.

Exit Button

The Exit button exits the Antenna Correction Factors window. Use the Save button to save any changes you have made prior to exiting.

GPIB Configuration Window

The GPIB Configuration window is used to select the card type, card address and the spectrum analyzer address.

GPIB Interface Card Selection Area

The GPIB Interface Card Selection area is used to select the type of interface card installed in the Personal Computer.

National GPIB/HPIB Address Area

The National GPIB/HPIB Address area is used to select the card type for either the GPIB or HP-IB card, and also the address of the spectrum analyzer.

Card Text Box

The Card text box is used to select the card type for GPIB or HP-IB interface cards.

AT-GPIB cards will most likely be set to "0". To verify this setting, use one of the following procedures:

■ Windows 3.1

From the Main group icon, double-click on Control Panel, then GPIB. Verify that GPIB0 is highlighted in the GPIB Board list box.

■ For Windows 95

From the Start menu, click on Settings, Control Panel, then GPIB. Verify that GPIB0 is highlighted in the GPIB Board list box.

HP-IB cards will most likely be set to the default I/O configuration setting of HPIB7. To verify this setting, use one of the following procedures:

■ Windows 3.1

From the HP SIC1 group, select the I/O Config utility. In the Configured Interfaces area, verify that the HPIB is set to 7.

■ Windows 95

From the Start menu, click on Programs, HPI_O LIBRARIES, I_O Config. In the Configured Interfaces area, verify that the HPIB is set to 7.

For more information on setting up the GPIB or HPIB interface cards, refer to “Setting Up the HP-IB or GPIB Interface” found earlier in this chapter.

Device Text Box

The Device text box is used to set the HP-IB address of the HP 8564E spectrum analyzer. The spectrum analyzer is preset at the factory to 18. To verify this setting, press **PRESET**, **CONFIG**, **ANALYZER ADDRESS**.

Done Button

The Done button retains any changes made to the GPIB Configuration window then exits the GPIB Configuration window.

Customer Support

Your HP 84125C system is built to provide dependable service. Hewlett-Packard's worldwide sales and service organization is ready to provide the support you need. The following support-related information is provided in this chapter.

- If You Have a Problem
- Calibration Information
- Replaceable Parts
- HP Sales and Service Offices
 - Returning the HP 84125C System for Calibration or Service
 - Packaging the HP 84125C System for Shipment
 - Factory Return Service Sheet

If You Have a Problem

If you have a problem, refer to the following for possible help:

- HP 84125C System User's Guide
 - Refer to "System Functional Tests" in Chapter 3.
- Return the FAX Cover Sheet

A FAX sheet is provided at the end of this chapter as a method in which to directly contact the HP EMC support team in the event of a problem. The FAX cover sheet provides the EMC support team with information about your company, the product, and a detailed description about the problem.

Simply copy the FAX cover sheet, fill out the requested information, include any additional information sheets, and FAX the sheet(s) to HP EMC Support at (707) 577-4200. Depending on the complexity of the problem, you should receive a response back within a few days.

Calibration Information

Hewlett-Packard recommends that the HP 84125C system be calibrated in 1-year intervals. Return the system to the nearest HP Sales and Service office listed in Table 8-2.

A system calibration should be performed when any of the system individual instruments or components are repaired or replaced.

Replaceable Parts

Table 8-1. Replaceable Parts

| Part Description | Part Number | Quantity | Reference Designator |
|--|-------------|----------|----------------------|
| Double-Ridged Horn Antenna, 1 to 18 GHz | HP 11966E | 1 | |
| Standard Gain Horn Antenna, 18 to 26.5 GHz | 84125-80008 | 1 | |
| Standard Gain Horn Antenna, 26.5 to 40 GHz | 84125-80001 | 1 | |
| Antenna Clamp | 84125-20026 | 1 | |
| Amplifier ¹ | HP 83051A | 2 | |
| DC Power Supply | HP 87421A | 2 | |
| High-Pass Filter, 1.5 GHz ¹ | 84300-80037 | 1 | |
| High-Pass Filter, 3.5 GHz ¹ | 84300-80038 | 1 | |
| High-Pass Filter, 8.25 GHz ¹ | 84300-80039 | 1 | |
| Filter Clamp | 84125-20027 | | |
| Clamp Thumb Screw | 0515-2212 | | |
| RF Cable, semirigid ¹ | 84125-20041 | 1 | W1 |
| RF Cable, semirigid ¹ | 84125-20042 | 1 | W2 |
| RF Cable, semirigid ¹ | 84125-20043 | 1 | W3 |
| RF Cable, semirigid ¹ | 84125-20044 | 1 | W4 |
| RF Cable, semirigid ¹ | 84125-20045 | 1 | W5 |
| RF Cable, semirigid ¹ | 84125-20019 | 1 | W9 |
| RF Cable, assembly ¹ | 84125-60002 | 1 | |
| Adapter, SMA (m) to (m) | 1250-1159 | 1 | |
| Adapter, 2.4 mm (f) to (f) | 1250-2589 | 1 | J1 |
| Adapter, 2.92 mm (f) to (f) | 1250-2182 | 1 | J2,J3 |
| Torque Wrench, 5/16 inch 8-in lb | 8710-1623 | 1 | |

¹ If this component is repaired or replaced, a system calibration must be performed to ensure accurate measurement.

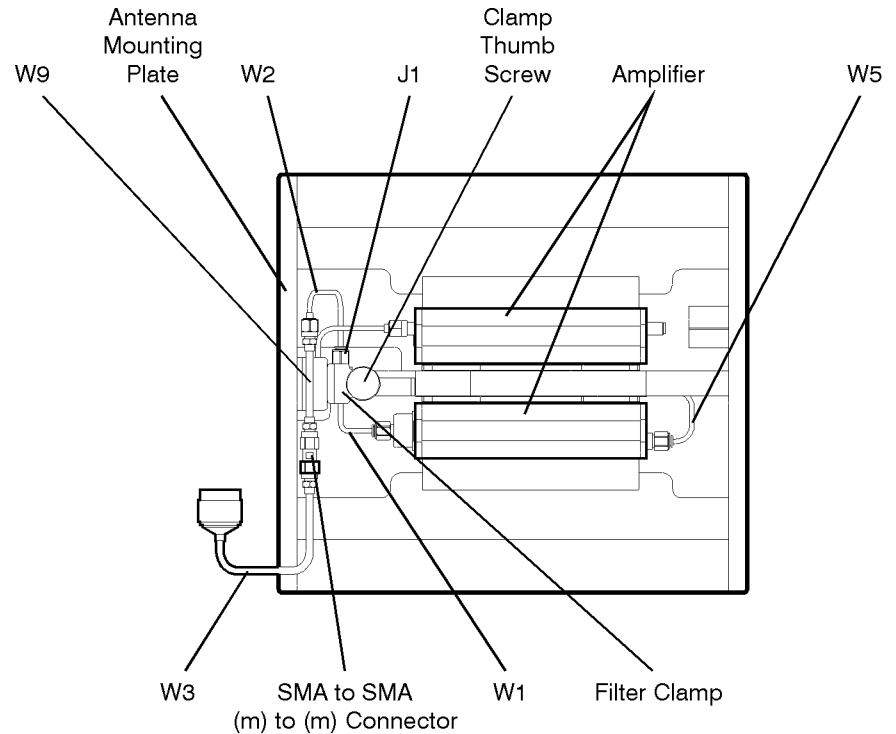

rplpart

Figure 8-1. Component Location Diagram

Returning the HP 84125C System for Calibration or Service

Use the information in this section to return the HP 84125C system to Hewlett-Packard.

Note

When returning the HP 84125C system for calibration, the spectrum analyzer with the HP 84125C Download Utility disk and the test set including all cables, filters, and antenna(s) should be returned to the Hewlett-Packard Sales and Service office. We recommend that you return the spectrum analyzer, test set, and 1 to 18 GHz antenna in their original packaging containers.

Packaging the HP 84125C System for Shipment

Use the following steps to package the HP 84125C system for shipment to Hewlett-Packard for calibration or service:

1. If the HP 84125C system is being sent in for repair, include the following information:
 - Any specific information regarding the nature of the problem.
 - Any error messages that appear on the spectrum analyzer display.
 - Any specific data on the performance of the HP 84125C system.

CAUTION

Damage to the HP 84125C system can result from using packaging materials other than those specified. Never use styrene pellets in any shape as packaging materials. They do not adequately cushion the instrument or prevent it from shifting in the carton. Styrene pellets cause equipment damage by generating static electricity and by lodging in the fan.

2. Use the original packaging materials or strong containers that are made of double-walled, corrugated cardboard with 159 kg (350 lb) bursting strength. The cartons must be large enough and strong enough and allow at least 3 to 4 inches on all sides of the instrument for packing material.
3. Protect the front panel of the spectrum analyzer with cardboard.
4. Surround the spectrum analyzer and test set with at least 3 to 4 inches of packing material, or enough to prevent them from moving in the carton. If packing foam is not available, the best alternative is SD-240 Air Cap™ from Sealed Air Corporation (Commerce, CA 90001). Air Cap looks like a plastic sheet covered with 1-1/4 inch air-filled bubbles. Use the pink Air Cap to reduce static electricity. Wrap the instrument several times in the material to both protect the instrument and prevent it from moving in the carton.
5. Seal the shipping container securely with strong nylon adhesive tape.
6. Mark the shipping container “FRAGILE, HANDLE WITH CARE” to ensure careful handling.
7. Retain copies of all shipping papers.

Hewlett-Packard Sales and Service Offices

Sales and service offices are located around the world to provide complete support for your HP 84125C system. To obtain servicing information or to order replacement parts, contact your nearest Hewlett-Packard Sales and Service office listed in Table 8-2. In any correspondence or telephone conversations, refer to the HP 84125C system by its model number and full serial number. With this information, the HP representative can quickly determine whether your unit is still within its warranty period.

Any adjustment, maintenance, or repair of this product must be performed by qualified personnel. Contact your local HP Sales and Service Office.

Table 8-2. HP Sales and Service Offices

US Field Operation Headquarters

Hewlett-Packard Company
19320 Pruneridge Avenue
Cupertino, CA 95014 USA
(800) 752-0900

Georgia

Hewlett-Packard Company
2000 South Park Place
Atlanta, GA 30339
(404) 955-1500

Southern California

Hewlett-Packard Company
1421 South Manhattan Avenue
Fullerton, CA 92631
(714) 999-6700

Illinois

Hewlett-Packard Company
5201 Tollview Drive
Rolling Meadows, IL 60008
(708) 342-2000

Northern California

Hewlett-Packard Company
301 E. Evelyn
Mountain View, CA 94041
(415) 694-2000

New Jersey

Hewlett-Packard Company
150 Green Pond Road
Rockaway, NJ 07866
(800) 403-0801

Colorado

Hewlett-Packard Company
24 Inverness Place
East Englewood, CO 80112
(303) 649-5000

Texas

Hewlett-Packard Company
930 E. Campbell Road
Richardson, TX 75081
(214) 231-6101



FAX Cover Sheet

To: HP EMC Support FAX Number: (707)577-4200 Page ____ of ____

Date Transmitted: _____ Time Transmitted: _____

From:

Company: _____

Last Name: _____ First Name: _____

Address: _____

City: _____ State: _____

Country: _____ Postal Code: _____ Mail Stop: _____

Telephone Number (Include Country Code): _____

FAX Number (required): _____

E-Mail Address: _____

.....
DLP Revision Number: _____
.....

Model Number:

HP 84125A

HP 84125B

HP 84125C

.....
Can the problem be reproduced? Yes No

Detailed Problem Description: _____

Amplitude Accuracy

The amplitude accuracy of the HP 84125C system is a combination of the accuracy of the spectrum analyzer and the accuracy of the test set including the RF cable assembly. In general, the amplitude error is calculated by:

$$[\text{Spectrum Analyzer Uncertainty}] + [\text{Test-Set Uncertainty}] + [\text{Temperature Drift}^*] = \text{Total Uncertainty}$$

*Where temperature drift is the maximum specified test set temperature drift.

Spectrum Analyzer Uncertainties

- **Calibrator amplitude uncertainty** is the difference between the actual level of the front-panel calibrator and the nominal level (−10 dBm).
- **Analyzer flatness uncertainty** is caused by the imperfect frequency response of the spectrum analyzer. This error is the difference between the analyzer response at the measurement frequency and the response at the calibrator frequency.
- **Analyzer attenuator uncertainty** occurs when the spectrum analyzer attenuator is set to a value other than the 10 dB factory calibration setting. This optimizes the HP 84125C system for highest dynamic range.
- **Reference level uncertainty** is caused by the addition of IF gain in the measuring analyzer. It occurs when the reference level of the spectrum analyzer is set to a value other than 87 dB μ V. The spectrum analyzer reference level is equal to the displayed reference level (in dB μ V) plus the system correction factor. This can be read directly from the spectrum analyzer by turning the correction factors off.
- **Resolution bandwidth switching uncertainty** is associated with the stability and switching of the resolution bandwidth filters in the spectrum analyzer.
- **Analyzer scale fidelity uncertainty** occurs when measuring a signal when its amplitude is below the top graticule of the display. This can be minimized by adjusting the reference level so that the peak of the signal is at the top of the screen.

HP 84125C Test-Set Uncertainties

- **Antenna factor uncertainty** is the antenna manufacturer's uncertainty of characterizing the antenna factor.
- **Antenna mismatch uncertainty** is caused by the VSWR pattern created when the antenna is connected to the test-set input. The magnitude of this error depends on the VSWR of both the antenna and the test set.
- **Calibration data uncertainty** is a measure of the uncertainty of the factory calibration of the HP 84125C test set at the calibration frequencies.
- **Test-set flatness uncertainty** includes the mismatch error between the spectrum analyzer input and test-set output plus the maximum interpolation error that occurs when making measurements at frequencies other than the calibration frequencies.
- **Test-set repeatability uncertainty** consists of the errors caused by the RF cable assembly being flexed, the amplifiers drifting between calibrations, and the repeatability of the connectors used to interconnect the filters and the antennas.
- **Test-set maximum temperature drift uncertainty** is a maximum amplitude error that will occur due to temperature drift. This error is valid when the HP 84125C system is used in an ambient temperature range of 20 C to 30 C.

To calculate the total amplitude uncertainty, the individual uncertainties described above must be combined. In combining them, we recommend following the procedure in the National Measurement Accreditation Service (NAMAS), Publication NIS 81. (NAMAS is now known as United Kingdom Accreditation Service, UKAS.)

This publication specifically addresses the calculation of measurement uncertainty in EMC measurements. This procedure involves the following steps:

1. Determine the type of each uncertainty and its probability distribution.
2. Convert each uncertainty to a "standard" uncertainty. Refer to NAMAS, publication NIS 81.
3. Combine the standard uncertainties by either using Root Sum Square (RSS) or direct addition depending on whether it is random or systematic, and whether or not they are correlated with each other.
4. Multiply your result by a factor (typically 1 to 3) to arrive at the desired confidence level for your measurement. The following example, uses 2 which is recommended by NAMAS, Publication NIS 81. This factor corresponds to a confidence level of 95%.

The following example uses the 1 to 18 GHz antenna with the spectrum analyzer in Logarithmic-scale mode ((AMPLITUDE), LOG dB/DIV).

Measurement parameters for this example are:

| | |
|-----------------------------|------------------|
| Measurement frequency: | 18 GHz |
| Displayed signal amplitude: | 64 dB μ V |
| Reference level: | 74 dB μ V/m* |
| Resolution bandwidth: | 1 MHz |
| Input attenuation: | 0 dB |
| Antenna VSWR | 2.8:1 |
| Test-Set VSWR | 3.2:1 |

*Approximately 62 dB μ V for the spectrum analyzer. In Logarithmic mode, the spectrum analyzer reference level is found by turning off the correction data on the spectrum analyzer (CAL), MORE 1 OF 2, AMPCOR MENU AMPCOR ON OFF with OFF underlined). In Linear mode, the correction data is automatically turned off and the reference level can be read directly.

The measurement uncertainties are found in *HP 8560 E-Series Spectrum Analyzer Calibration Guide*. The measurement uncertainties for the spectrum analyzer using the instrument settings above are:

| | |
|---|---------|
| Calibrator uncertainty: | 0.3 dB |
| Analyzer flatness uncertainty: | 4.0 dB |
| Analyzer attenuator uncertainty: | 3.0 dB |
| Reference level uncertainty: | 1.0 dB |
| Resolution bandwidth switching uncertainty: | 0.5 dB |
| Analyzer scale fidelity uncertainty: | 0.85 dB |

The measurement uncertainties for the HP 84125C test set are found in Test Set and Antenna Factor Accuracy specifications found earlier in this chapter. The measurement uncertainties for the HP 84125C test set using the measurement parameters above are:

| | |
|---|--------|
| Antenna factor uncertainty | 2.0 dB |
| Antenna / test-set mismatch uncertainty | 2.4 dB |
| Calibration data uncertainty | 0.9 dB |
| Test-set flatness uncertainty | 1.7 dB |
| Test-set repeatability uncertainty | 0.7 dB |
| Test-set maximum temperature drift | 1.5 dB |

Table A-1 lists the uncertainties along with the required information to calculate the measurement uncertainty. Refer to NAMAS, Publication NIS 81 for the procedure on calculation of standard errors.

Table A-1. HP 84125C System Uncertainties

| Error Source | Where Obtained | Type of Limit | Type of Probability Distribution | Stated Limit | Standard Uncertainty |
|--|----------------------------------|--------------------------|---|---------------------|-----------------------------|
| HP 8564E Spectrum Analyzer Uncertainties | | | | | |
| Calibrator Uncertainty | spectrum analyzer specifications | 3 sigma specification | normal | 0.3 dB | 0.1 dB |
| Analyzer Flatness Uncertainty | spectrum analyzer specifications | 3 sigma specification | normal | 4.0 dB | 1.33 dB |
| Analyzer Attenuator Uncertainty | spectrum analyzer specifications | 3 sigma specification | normal | 3.0 dB | 1.0 dB |
| Reference Level Uncertainty | spectrum analyzer specifications | 3 sigma specification | normal | 1.0 dB | 0.33 dB |
| Resolution Bandwidth Switching Uncertainty | spectrum analyzer specifications | 3 sigma specification | normal | 0.5 dB | 0.17 dB |
| Analyzer Scale Fidelity Uncertainty | spectrum analyzer specifications | 3 sigma specification | normal | 0.85 dB | 0.28 dB |
| HP 84125C Test Set and System Uncertainties | | | | | |
| Antenna Factor Uncertainty | HP 84125C specifications | specification | assumed uniform | 2.0 dB | 1.16 dB |
| Antenna to Test Set Mismatch | HP 84125C specifications | calculated maximum error | U-shaped | 2.4 dB | 1.70 dB |
| Calibration data Uncertainty | HP 84125C specifications | 3 sigma specification | normal | 0.9 dB | 0.30 dB |
| Test Set Flatness Uncertainty | HP 84125C specifications | 3 sigma specification | normal | 1.7 dB | 0.57 dB |
| Test Set Repeatability Uncertainty | HP 84125C specifications | 3 sigma | normal | 0.7 dB | 0.23 dB |
| Test Set Temperature Drift (maximum) Uncertainty | HP 84125C specifications | 3 sigma | normal | 1.5 dB | applied directly |

To calculate the total system amplitude uncertainty, these uncertainties must be combined. The uncertainties which are random and uncorrelated (except for the test-set temperature drift uncertainty) will be combined using the Root Sum Square (RSS) method. This result will be multiplied by 2 to obtain a 95% confidence level. Then the test-set temperature drift uncertainty will be added to the result.

Therefore, the total standard error for this example is:

$$\sqrt{(.1)^2 + (1.33)^2 + (1.0)^2 + (.33)^2 + (.17)^2 + (.28)^2 + (1.16)^2 + (1.7)^2 + (.3)^2 + (.57)^2 + (.23)^2} = 2.77dB$$

The total amplitude uncertainty is:

$$2*(2.77) + 1.5 = 7.04 \text{ dB}$$

This is the total amplitude uncertainty in the measured field strength of the HP 84125C system for these measurement settings. The uncertainty for each set of measurement conditions must be calculated separately. It is recommended that you follow the procedure in NAMAS, Publication NIS 81 for calculating the amplitude uncertainty under your specific measurement conditions.

Index

- 1** 1 - 18 GHz test set configuration, 4-1
 - 1.5 GHz to 18 GHz, 5-4
 - 18 - 26.5 GHz test set configuration, 4-4
 - 18 GHz to 26.5 GHz, 5-5
 - 1 GHz to 18 GHz, 5-3

- 2** 26.5 - 40 GHz test set configuration, 4-6
 - 26.5 GHz to 40 GHz, 5-5

- 3** 3.5 GHz to 18 GHz, 5-4
 - 3.5 mm connections, 4-7

- 8** 8.25 GHz to 18 GHz, 5-4

- A** Add to Mkr List, 5-5
 - ADJUST LIMIT, 5-6
 - amplitude correction data, printing, 7-10
 - antenna correction factor editing, 7-11
 - antenna, installing, 4-1
 - antenna specifications and characteristics, 2-3

- C** cable care, 4-7
 - calibration information, 8-2
 - changing antenna correction factors, 7-11
 - changing test-set configurations, 4-1
 - CLEAR MKR LIST, 5-6
 - components checklist, 3-2
 - configuration
 - 1-18 GHz, 4-1
 - 18 - 26.5 GHz, 4-4
 - 26.5 - 40 GHz, 4-6
 - configuring the test set hardware, 4-1
 - connector care, 4-7
 - COPY DISPLAY, 5-6
 - correction data softkeys, 5-1
 - correction factor editing, 7-11
 - customer support, 8-1

- D** declaration of conformity, 2-8
- device
 - connecting, 4-7
 - disconnecting, 4-8
 - handling, 4-8
 - storage, 4-8
- disconnections, 4-8
- DLP
 - downloading, 7-10
 - reloading RAM card, 7-10
 - system interface, 5-1

- E** editing antenna correction factors, 7-11

- F** FCC measurement example, 6-1
- filter, installing, 4-1
- functional test, 3-10

- G** GPIB
 - configuration, 7-12
 - setting up, 7-2
 - setup for Windows 3.1, 7-5
 - software setup, Windows 3.1, 7-6
 - software setup, Windows NT 4.0, 7-8

- H** handling, 4-8
- Hewlett-Packard sales and service locations, 8-4
- HIGHEST PEAK, 5-6
- HP841254C Config, 5-6
- HP 84125C utility, 7-11
- HP-IB
 - configuration, 7-12
 - setting up, 7-2
 - setup for Windows 3.1, 7-2
 - setup for Windows 95, 7-3
 - setup for Windows NT 4.0, 7-4

- I** installation
 - AT-GPIB interface, 7-2
 - HP-IB interface, 7-2
- installing
 - antenna, 4-1
 - download utility, 7-10
 - filters, 4-1
 - system, 3-1
 - the system, 3-4
- interface card configurations, 7-12

- L** LIM LINE ON OFF, 5-7
loading correction data, 5-1

- M** making measurements, 6-1
MARKER dB μ V/m, 5-7
MAX HOLD ON OFF, 5-8
measurement
 - example, 6-1
 - overview, 1-2memory lost, reloading DLP, 7-10
minimum PC requirements, 7-2
MKR LIM ON OFF, 5-8

- N** NEXT LT PEAK, 5-9
NEXT PEAK, 5-8
NEXT RT PEAK, 5-9

- O** operation verification, 3-10

- P** packaging information, 8-3
parts list, replaceable, 8-2
PC requirements, 7-2
PRINT DISPLAY, 5-9
printing correction factors, 7-10
PRINT MKR LIST, 5-9
product description, 1-1

- R** regulatory information, 2-8
reloading the DLP, 7-10
repairing, system, 8-4
replaceable parts, 8-2
requirements
 - minimum PC, 7-2
 - PC, 7-2returning for repair, 8-4
returning the system, 8-3
returning to HP, 8-3

- S** SAVE MKR #1 - #9, 5-10
SELECT LINEAR, 5-10
SELECT LOG, 5-10
SERVICE, 5-11
service offices, HP, 8-4
service, returning for, 8-3
setting up
 - GPIB interface, 7-2
 - HP-IB interface, 7-2
 - system, 3-1shipping the system, 8-3
softkeys, system, 5-1
specifications, 2-1
storage, 4-8

- system
 - calibration, 8-2
 - characteristics, 2-1
 - components list, 3-2
 - description, 1-1
 - DLP, 5-1
 - functional test, 3-10
 - installation, 3-1, 3-4
 - returning, 8-4
 - setup, 3-1
 - softkeys, 5-1
 - specifications, 2-1
- system interface, 5-1

T test set

- components, 3-2
- configuration, 1-18 GHz, 4-1
- configuration, 18 - 26.5 GHz, 4-4
- configuration, 26.5 - 40 GHz, 4-6
- hardware configurations, 4-1

TIMEDATE ON OFF, 5-11

V VIEW MKR LIST, 5-11